

Neural Network Part 1: Multiple Layer Neural Networks

CS 760@UW-Madison





Goals for the lecture

you should understand the following concepts

- perceptrons
- the perceptron training rule
- linear separability
- multilayer neural networks
- stochastic gradient descent
- backpropagation

Neural networks

- a.k.a. *artificial neural networks, connectionist models*
- inspired by interconnected neurons in biological systems
 - simple processing units
 - each unit receives a number of real-valued inputs
 - each unit produces a single real-valued output

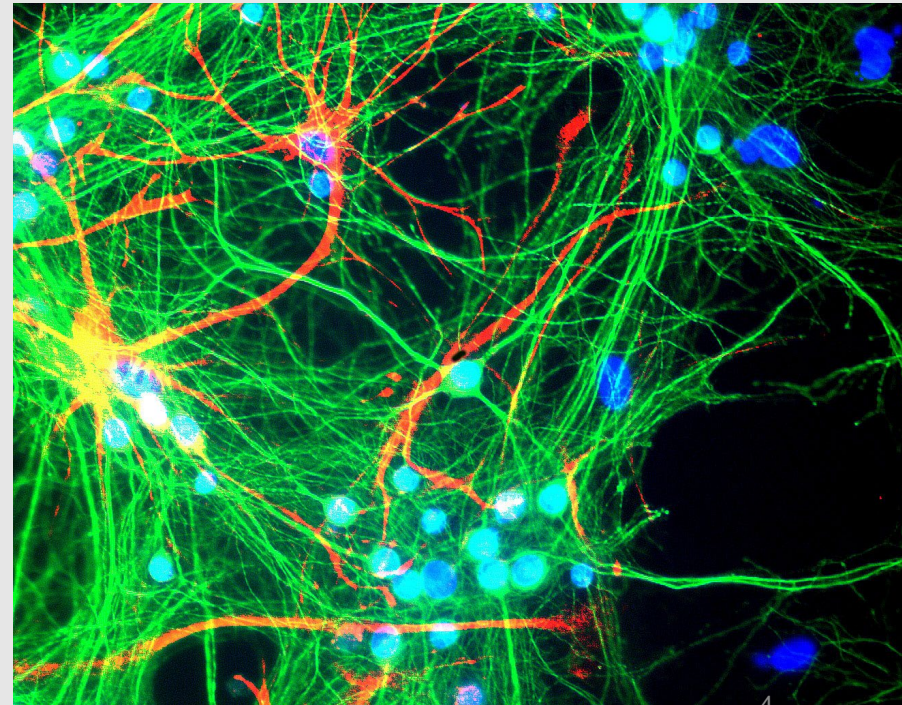
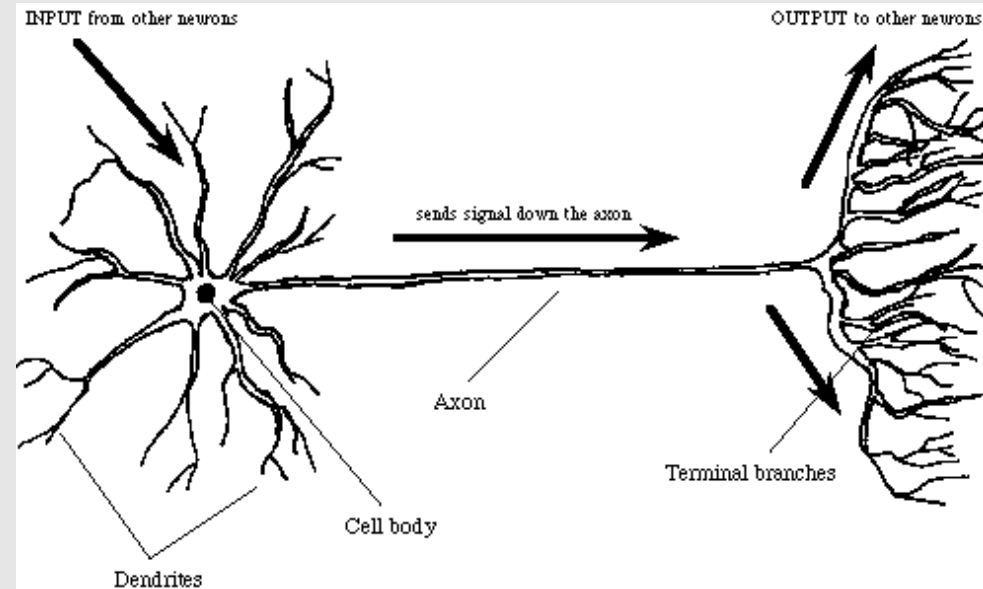

Perceptron



Perceptrons

[McCulloch & Pitts, 1943; Rosenblatt, 1959; Widrow & Hoff, 1960]

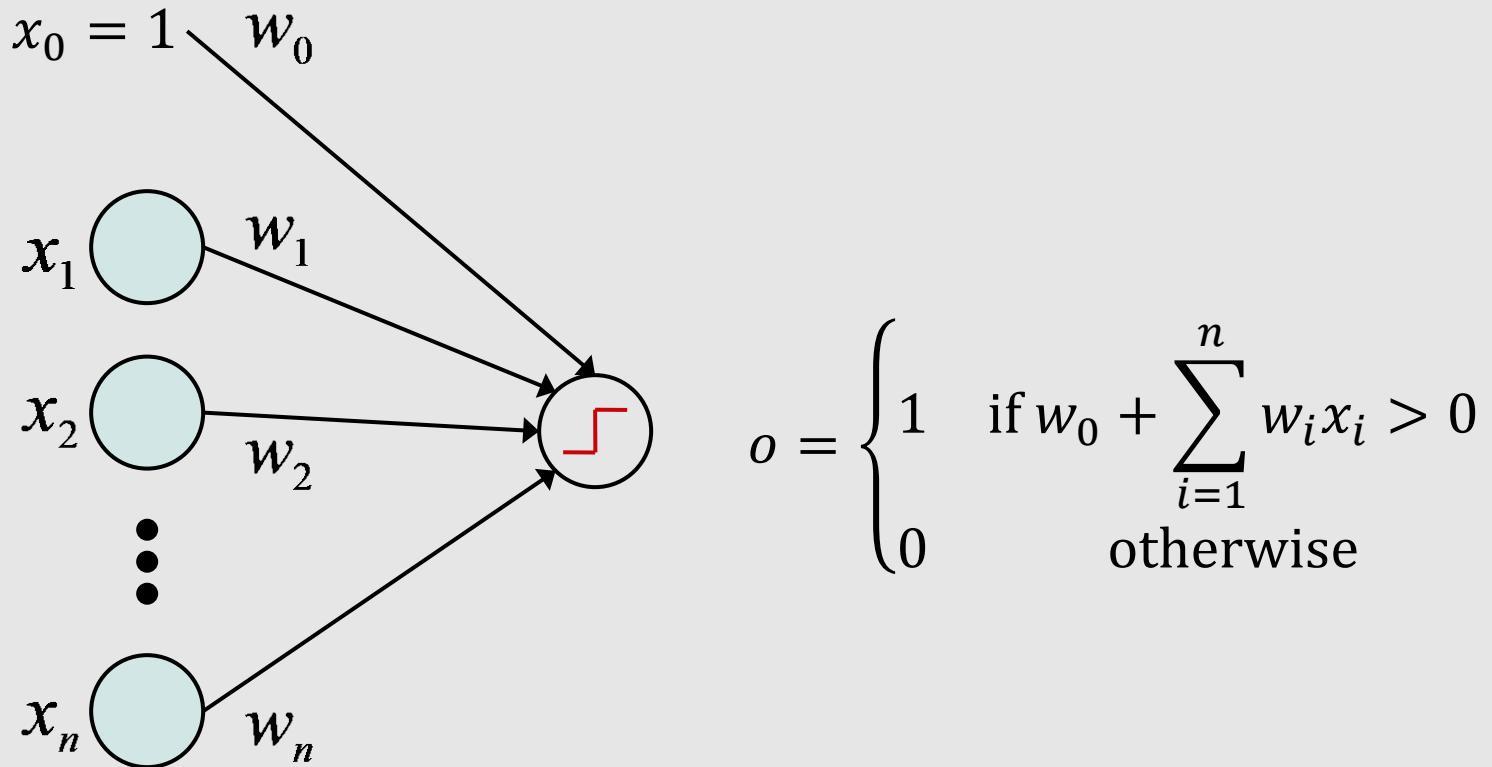

input units:
represent given x

output unit:
represents binary classification

The perceptron training rule



1. randomly initialize weights
2. iterate through training instances until convergence

2a. calculate the output for the given instance

$$o = \begin{cases} 1 & \text{if } w_0 + \sum_{i=1}^n w_i x_i > 0 \\ 0 & \text{otherwise} \end{cases}$$

2b. update each weight

$$\Delta w_i = \eta(y - o)x_i$$

η is *learning rate*;
set to value $\ll 1$

$$w_i \leftarrow w_i + \Delta w_i$$

Representational power of perceptrons



perceptrons can represent only *linearly separable* concepts

$$o = \begin{cases} 1 & \text{if } w_0 + \sum_{i=1}^n w_i x_i > 0 \\ 0 & \text{otherwise} \end{cases}$$

decision boundary given by:

$$1 \text{ if } w_0 + w_1 x_1 + w_2 x_2 > 0$$

also write as: $\mathbf{w}\mathbf{x} > 0$

$$w_1 x_1 + w_2 x_2 = -w_0$$

$$x_2 = -\frac{w_1}{w_2} x_1 - \frac{w_0}{w_2}$$

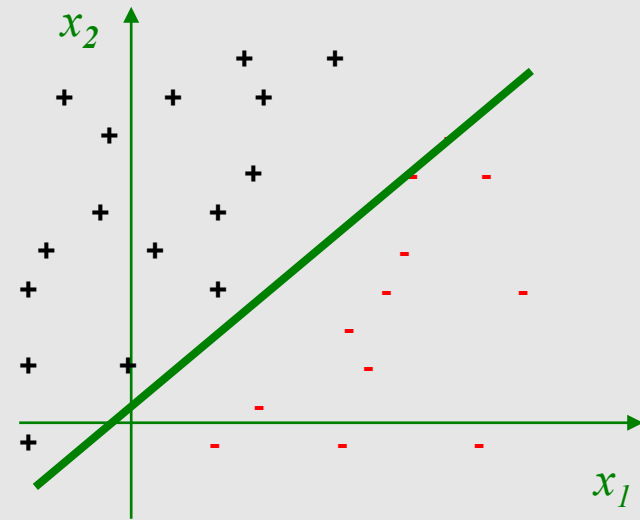

Representational power of perceptrons



- in previous example, feature space was 2D so decision boundary was a line
- in higher dimensions, decision boundary is a hyperplane

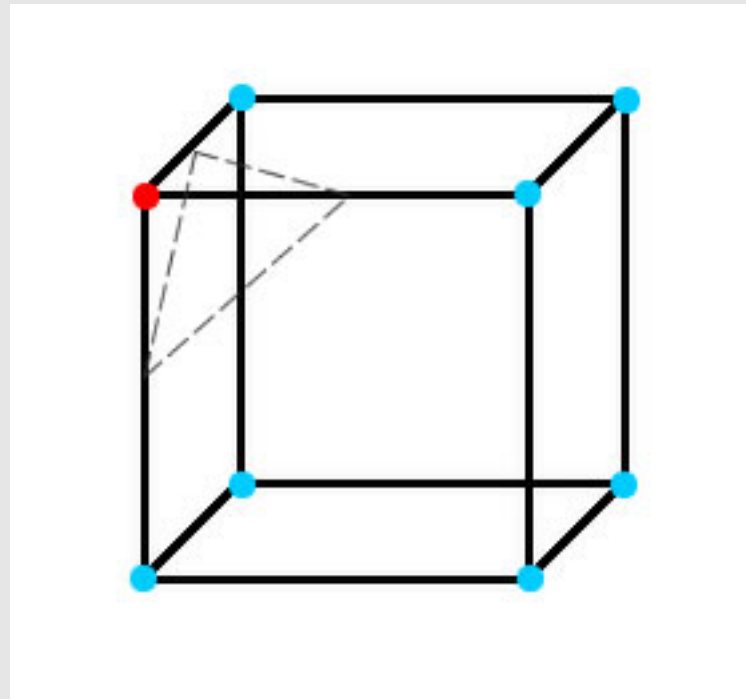

Some linearly separable functions



AND

	x_1	x_2	y
a	0	0	0
b	0	1	0
c	1	0	0
d	1	1	1

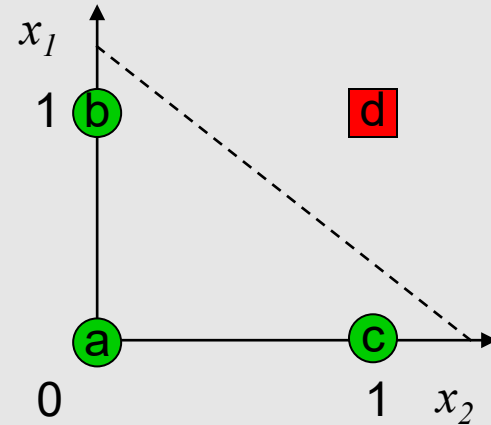

OR

	x_1	x_2	y
a	0	0	0
b	0	1	1
c	1	0	1
d	1	1	1

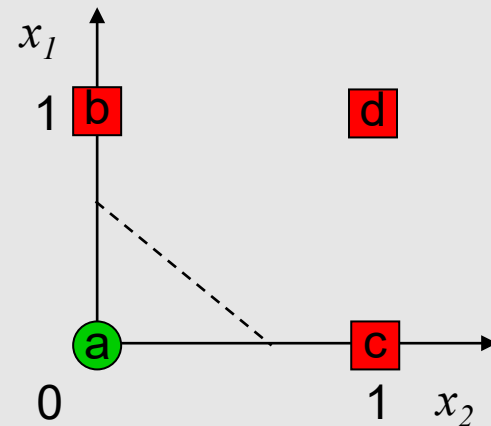



XOR is not linearly separable

	x_1	x_2	y
a	0	0	0
b	0	1	1
c	1	0	1
d	1	1	0

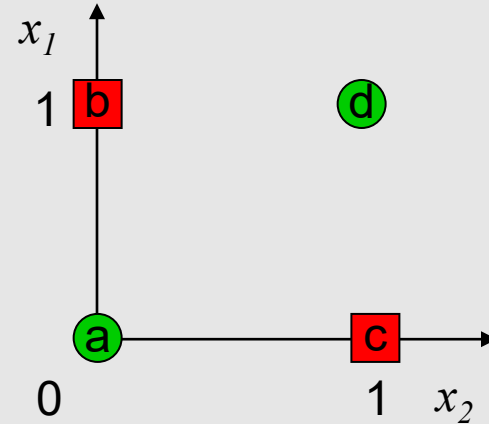

a multilayer perceptron
can represent XOR

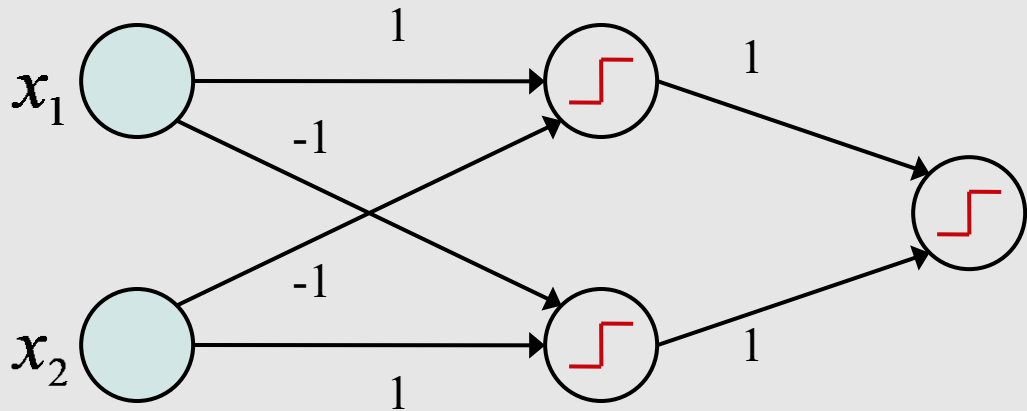

assume $w_0 = 0$ for all nodes

An aerial photograph of a city waterfront at sunset. The sun is low on the horizon, casting a golden glow over the city buildings and the water. The water is dark blue with many sailboats scattered across it. The city buildings are visible on the left side of the image, and the water extends to the right.

Multiple Layer Neural Networks



Example multilayer neural network

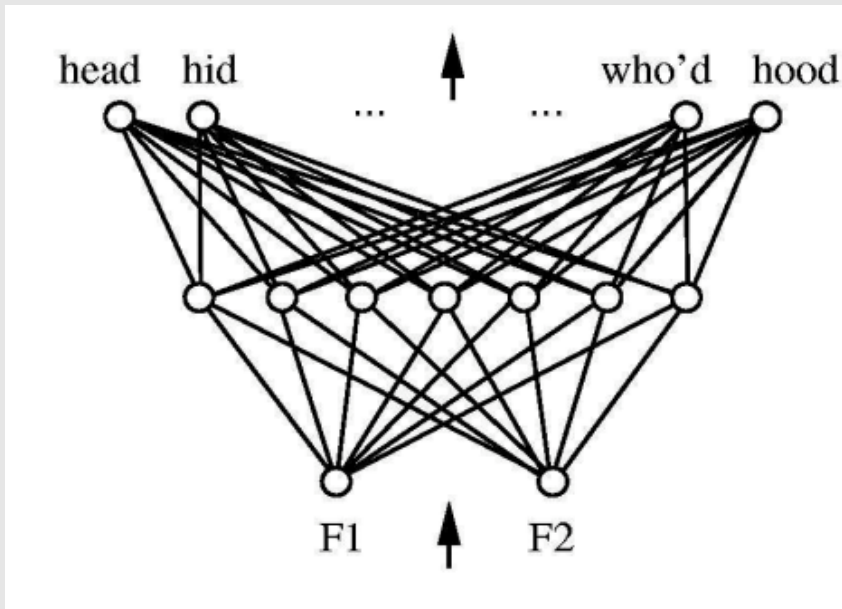

output units

hidden units

input units

figure from Huang & Lippmann, *NIPS* 1988

input: two features from spectral analysis of a spoken sound

output: vowel sound occurring in the context “h__d”

Decision regions of a multilayer neural network

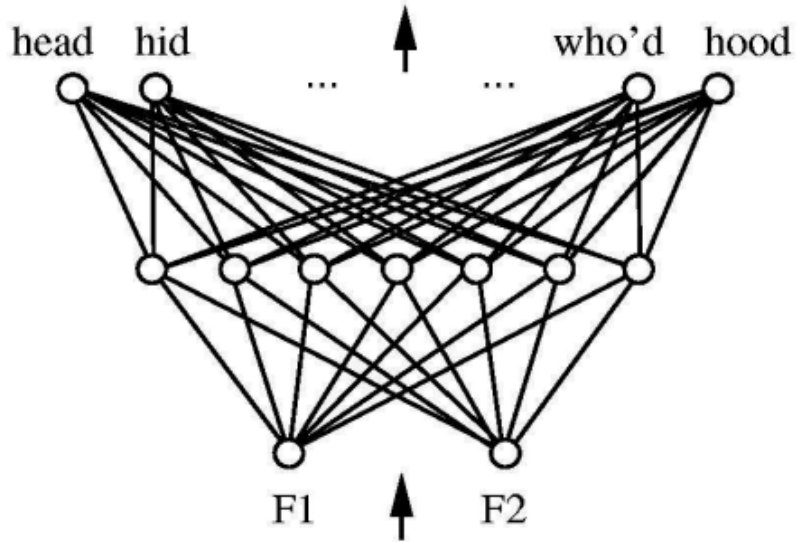
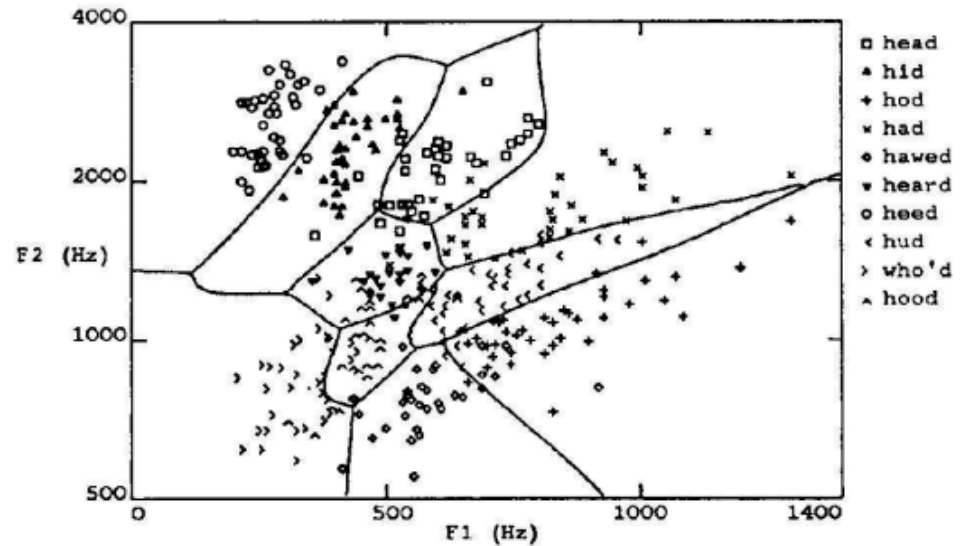

figure from Huang & Lippmann, *NIPS* 1988



input: two features from spectral analysis of a spoken sound

output: vowel sound occurring in the context “h__d”

Components



- Representations:
 - Input
 - Hidden variables
- Layers/weights:
 - Hidden layers
 - Output layer

Components

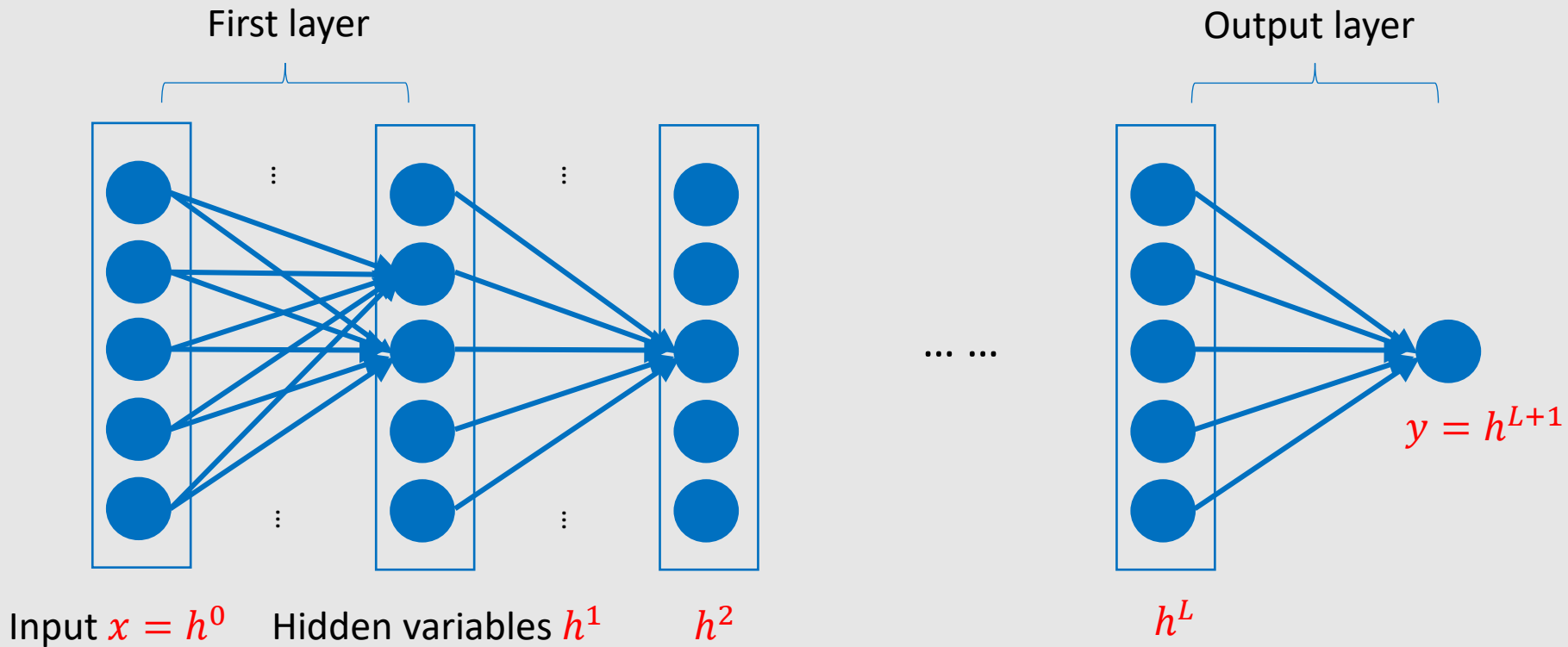

An $(L + 1)$ -layer network

A three-layer neural network

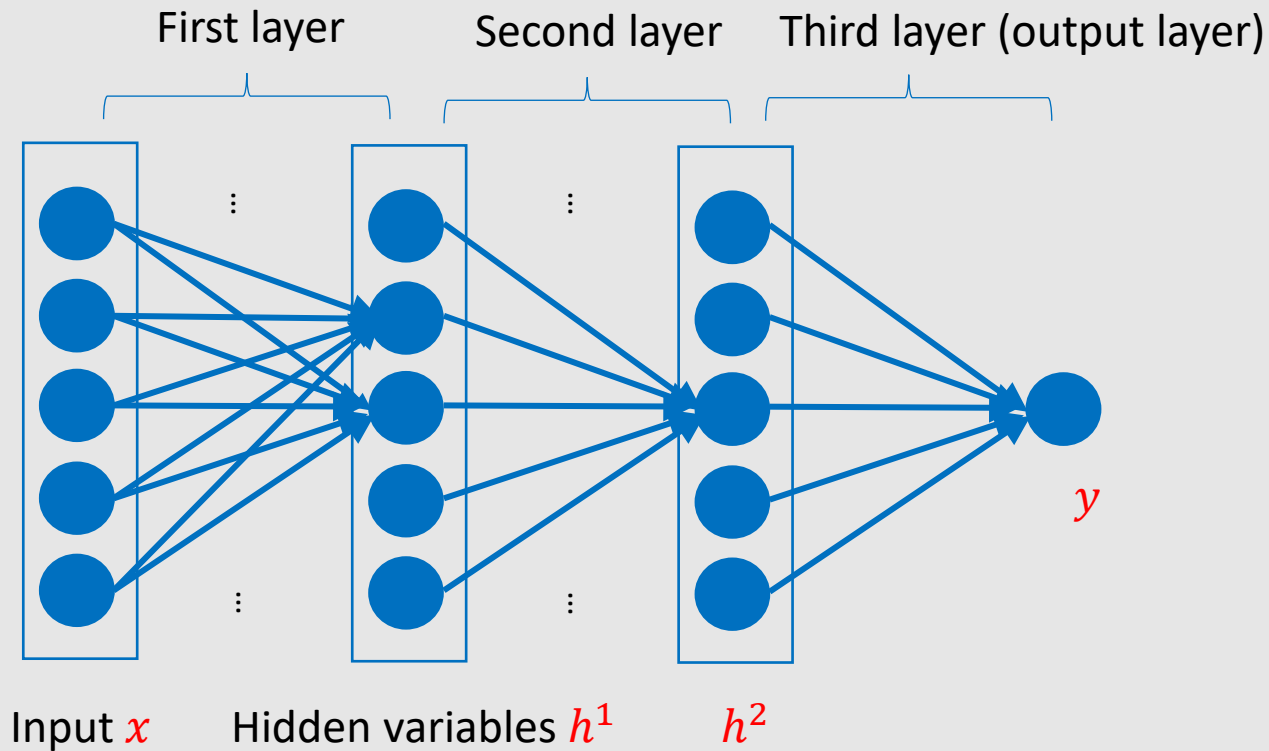

Input



- Represented as a vector
- Sometimes require some preprocessing, e.g.,
 - Subtract mean
 - Normalize to $[-1,1]$



Expand
→





Input (feature) encoding for neural networks

nominal features are usually represented using a *1-of-k* encoding

$$A = \begin{bmatrix} 1 \\ 0 \\ 0 \\ 0 \end{bmatrix} \quad C = \begin{bmatrix} 0 \\ 1 \\ 0 \\ 0 \end{bmatrix} \quad G = \begin{bmatrix} 0 \\ 0 \\ 1 \\ 0 \end{bmatrix} \quad T = \begin{bmatrix} 0 \\ 0 \\ 0 \\ 1 \end{bmatrix}$$

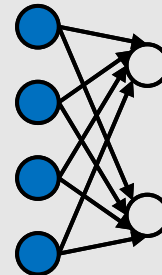

ordinal features can be represented using a *thermometer* encoding

$$\text{small} = \begin{bmatrix} 1 \\ 0 \\ 0 \end{bmatrix} \quad \text{medium} = \begin{bmatrix} 1 \\ 1 \\ 0 \end{bmatrix} \quad \text{large} = \begin{bmatrix} 1 \\ 1 \\ 1 \end{bmatrix}$$

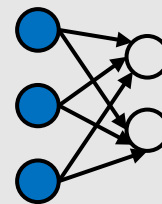

real-valued features can be represented using individual input units (we may want to scale/normalize them first though)

$$\text{precipitation} = [0.68]$$

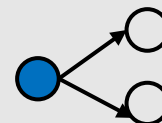

Output layers



- Regression: $y = w^T h + b$
- Linear units: no nonlinearity

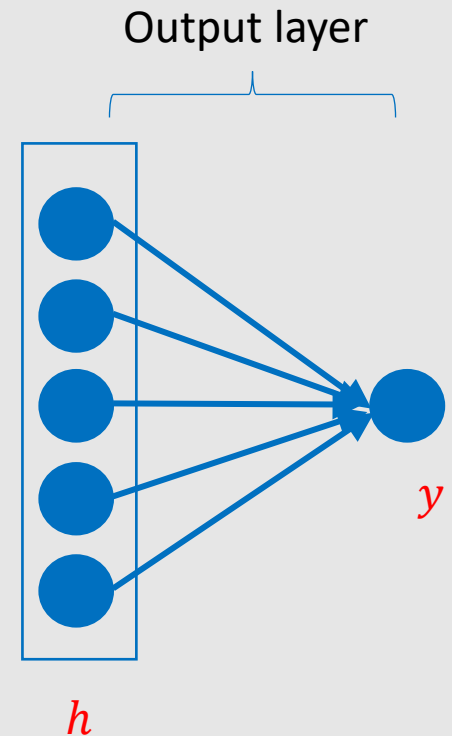

Output layers



- Multi-dimensional regression: $y = W^T h + b$
- Linear units: no nonlinearity

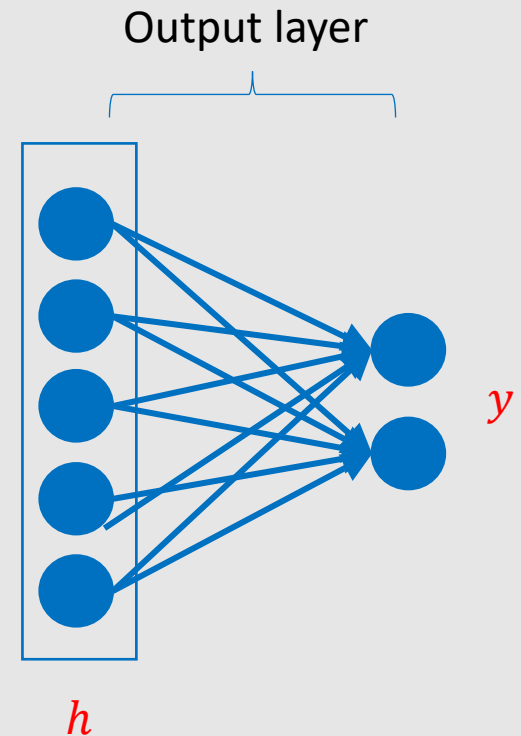

Output layers



- Binary classification: $y = \sigma(w^T h + b)$
- Corresponds to using logistic regression on h

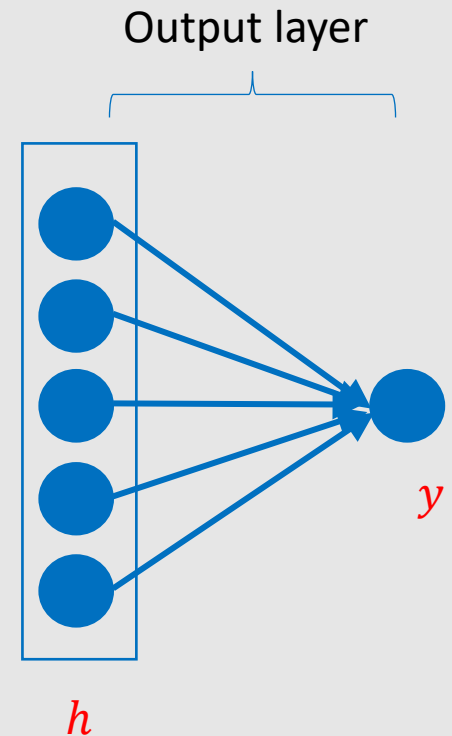

Output layers



- Multi-class classification:
- $y = \text{softmax}(z)$ where $z = W^T h + b$
- Corresponds to using multi-class logistic regression on h

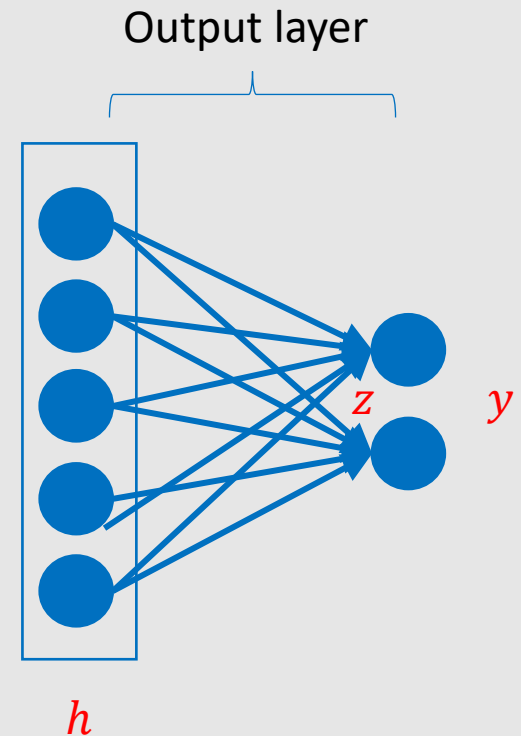

Hidden layers

- Neuron takes weighted linear combination of the previous representation layer
- outputs one value for the next layer

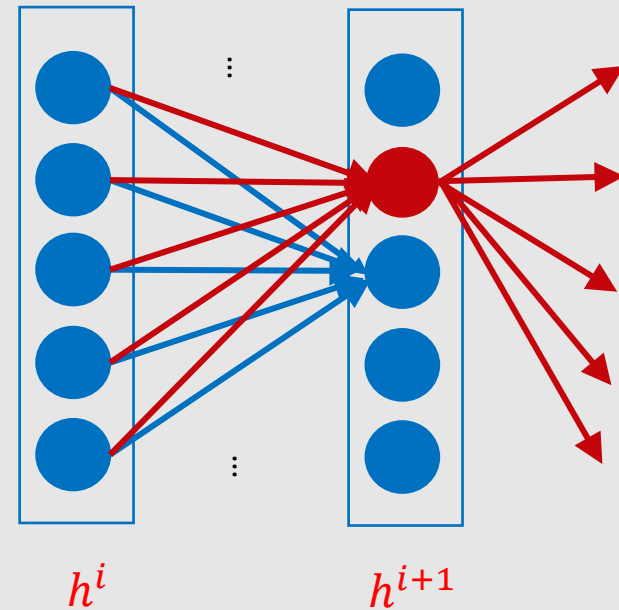



Hidden layers

- $a = r(w^T x + b)$
- Typical activation function r
 - Threshold $t(z) = \mathbb{I}[z \geq 0]$
 - Sigmoid $\sigma(z) = 1/(1 + \exp(-z))$
 - Tanh $\tanh(z) = 2\sigma(2z) - 1$

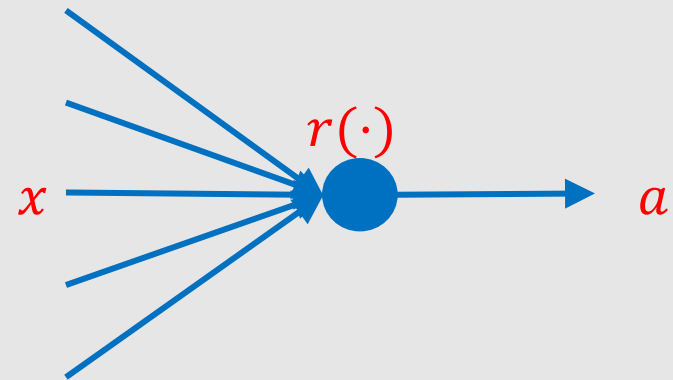



Hidden layers

- Problem: saturation

Too small gradient

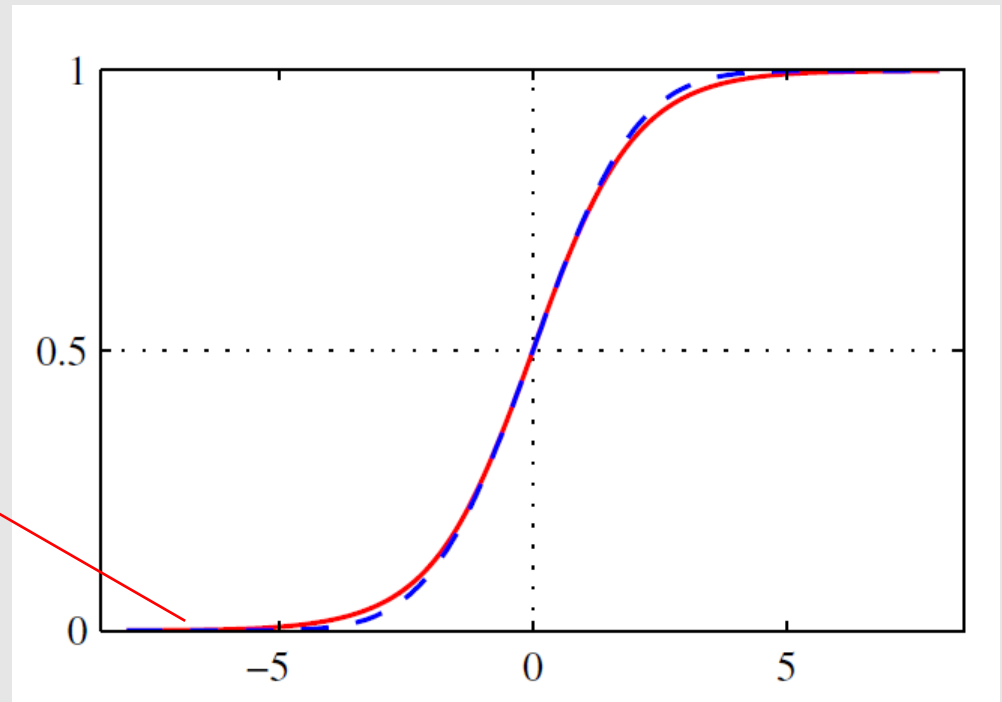

Figure borrowed from *Pattern Recognition and Machine Learning*, Bishop



Hidden layers

- Activation function ReLU (rectified linear unit)
 - $\text{ReLU}(z) = \max\{z, 0\}$

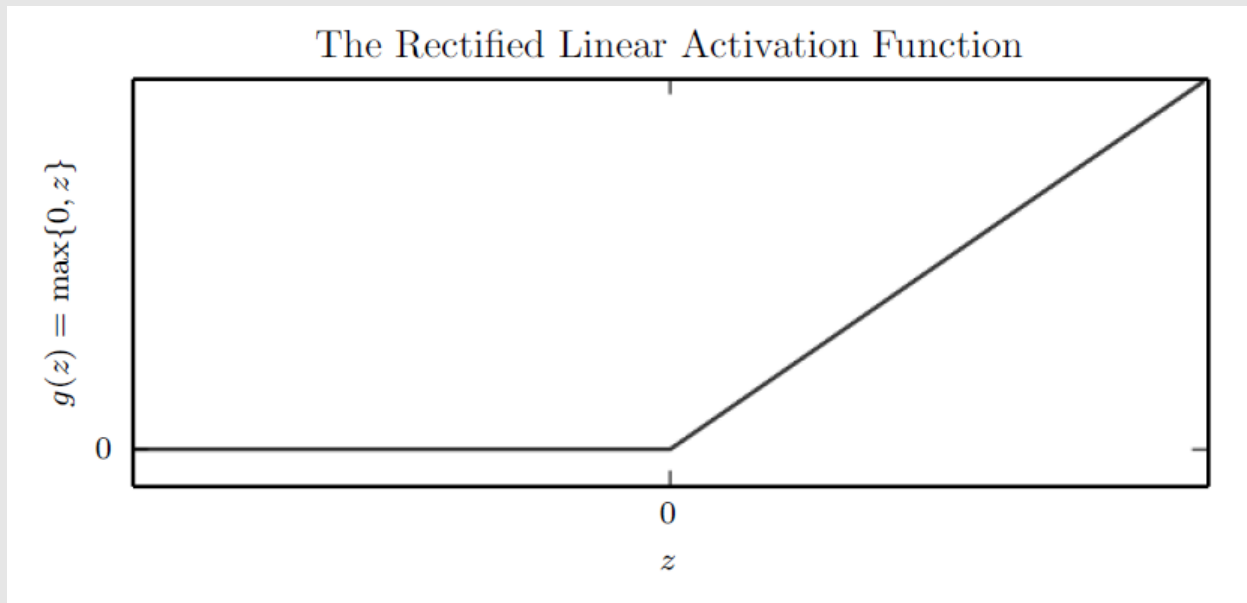

Figure from *Deep learning*, by Goodfellow, Bengio, Courville.



Hidden layers

- Activation function ReLU (rectified linear unit)

- $\text{ReLU}(z) = \max\{z, 0\}$

Gradient 1

Gradient 0

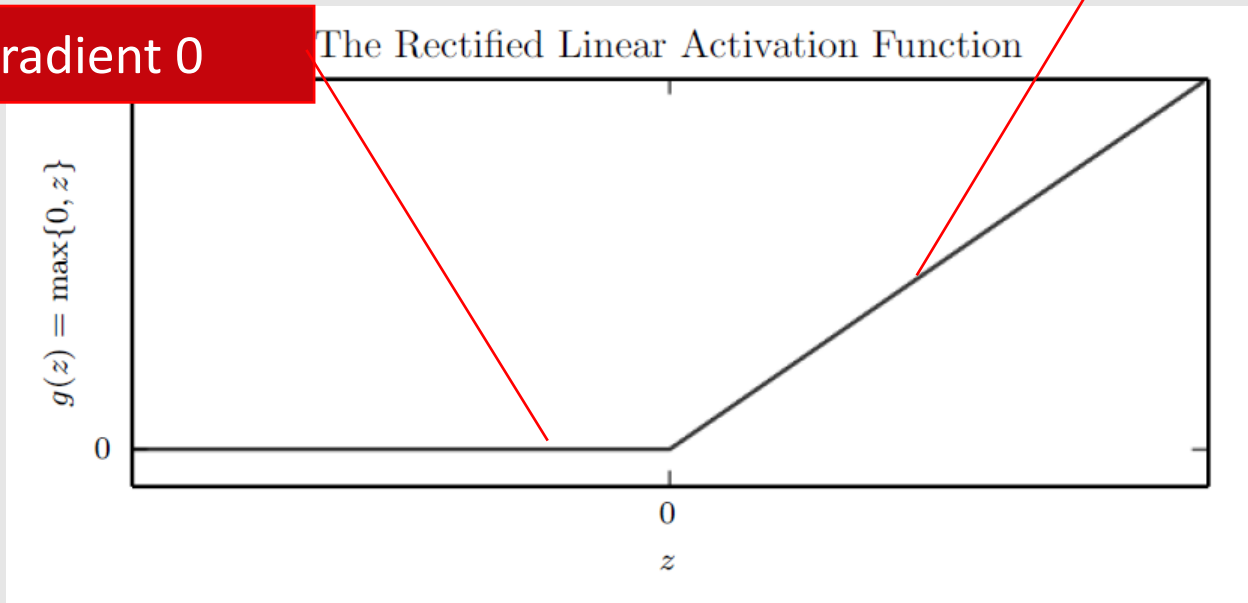

Hidden layers



- Generalizations of ReLU $\text{gReLU}(z) = \max\{z, 0\} + \alpha \min\{z, 0\}$
 - Leaky-ReLU(z) = $\max\{z, 0\} + \alpha \min\{z, 0\}$ for a constant $\alpha \in (0,1)$
 - Parametric-ReLU(z): α learnable

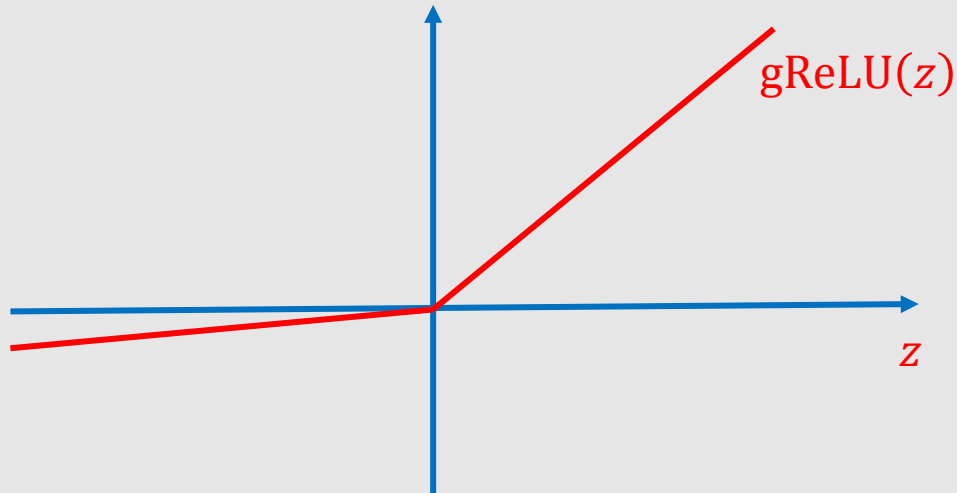

An aerial photograph of a city at sunset. The sun is low on the horizon, casting a golden glow over the city and the water. The city buildings are silhouetted against the bright sky. The water is dark blue with many sailboats scattered across it. The overall scene is peaceful and scenic.

Training Neural Networks with Gradient Descent: Backpropagation



Learning in multilayer networks

- work on neural nets fizzled in the 1960's
 - single layer networks had representational limitations (linear separability)
 - no effective methods for training multilayer networks

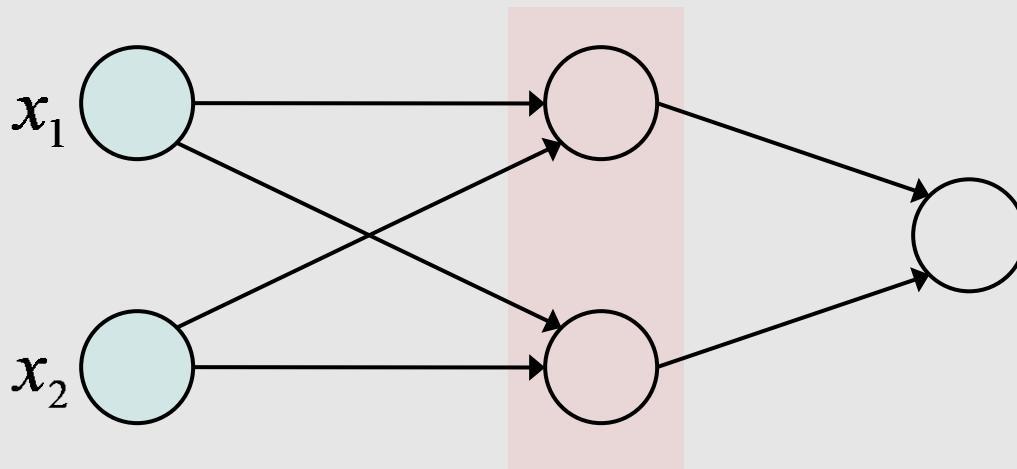

how to determine
error signal for
hidden units?

- revived again with the invention of *backpropagation* method [Rumelhart & McClelland, 1986; also Werbos, 1975]
 - key insight: require neural network to be differentiable; use *gradient descent*



Learning in multilayer networks

- learning techniques nowadays
 - random initialization of the weights
 - stochastic gradient descent (can add momentum)
 - regularization techniques
 - norm constraint
 - dropout
 - batch normalization
 - data augmentation
 - early stopping
 - pretraining
 - ...

Gradient descent in weight space

Given a training set $D = \{(x^{(1)}, y^{(1)}), \dots, (x^{(m)}, y^{(m)})\}$ we can specify an error measure that is a function of our weight vector \mathbf{w}

$$E(\mathbf{w}) = \frac{1}{2} \sum_{d \in D} (y^{(d)} - o^{(d)})^2$$

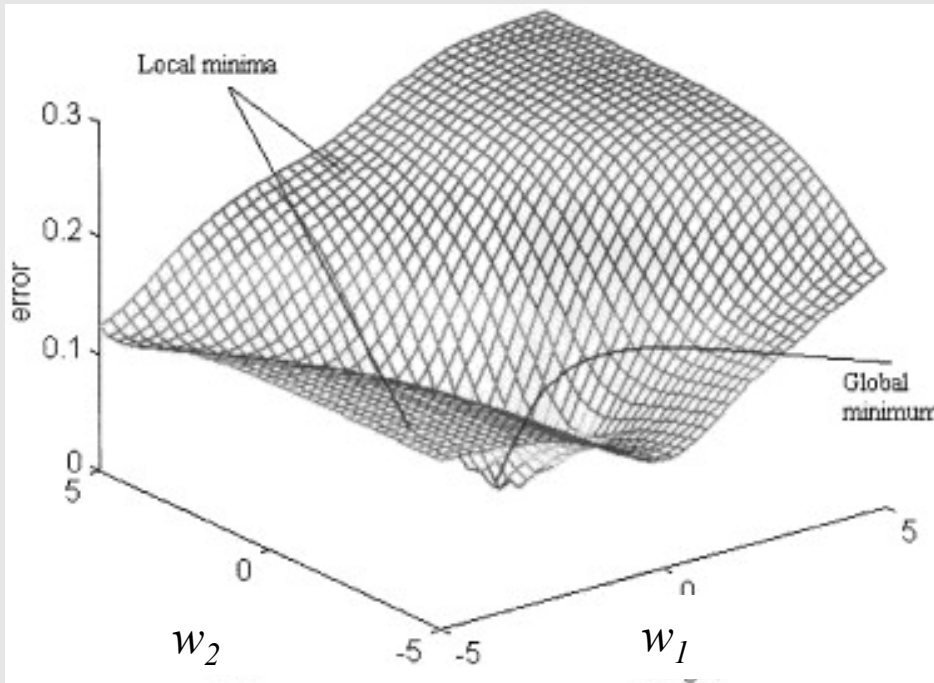

figure from Cho & Chow, *Neurocomputing* 1999

This error measure defines a surface over the hypothesis (i.e. weight) space

Gradient descent in weight space



gradient descent is an iterative process aimed at finding a minimum in the error surface

on each iteration

- current weights define a point in this space
- find direction in which error surface descends most steeply
- take a step (i.e. update weights) in that direction

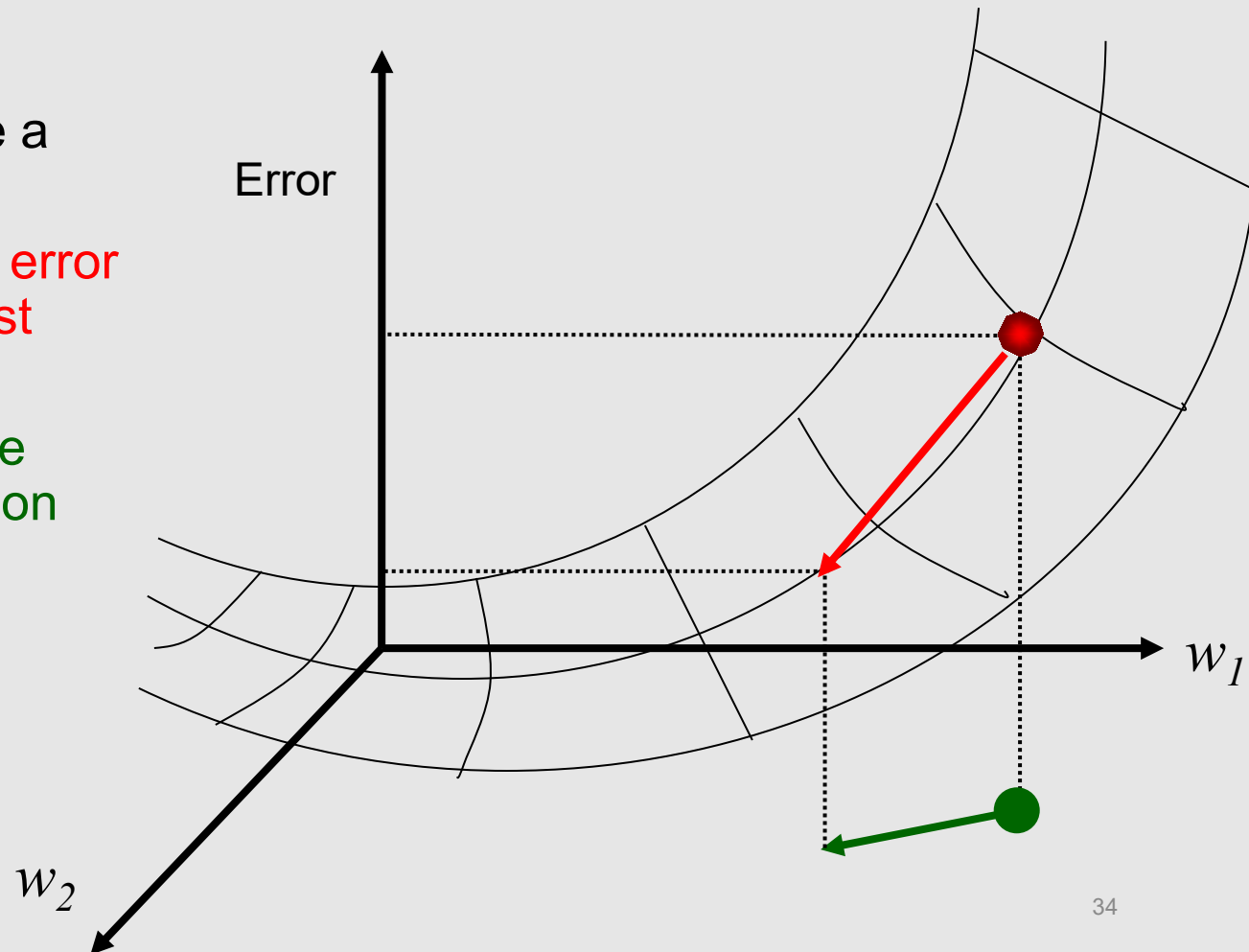



Gradient descent in weight space

calculate the gradient of E :
$$\nabla E(\mathbf{w}) = \left[\frac{\partial E}{\partial w_0}, \frac{\partial E}{\partial w_1}, \dots, \frac{\partial E}{\partial w_n} \right]$$

take a step in the opposite direction

$$\Delta \mathbf{w} = -\eta \nabla E(\mathbf{w})$$

$$\Delta w_i = -\eta \frac{\partial E}{\partial w_i}$$

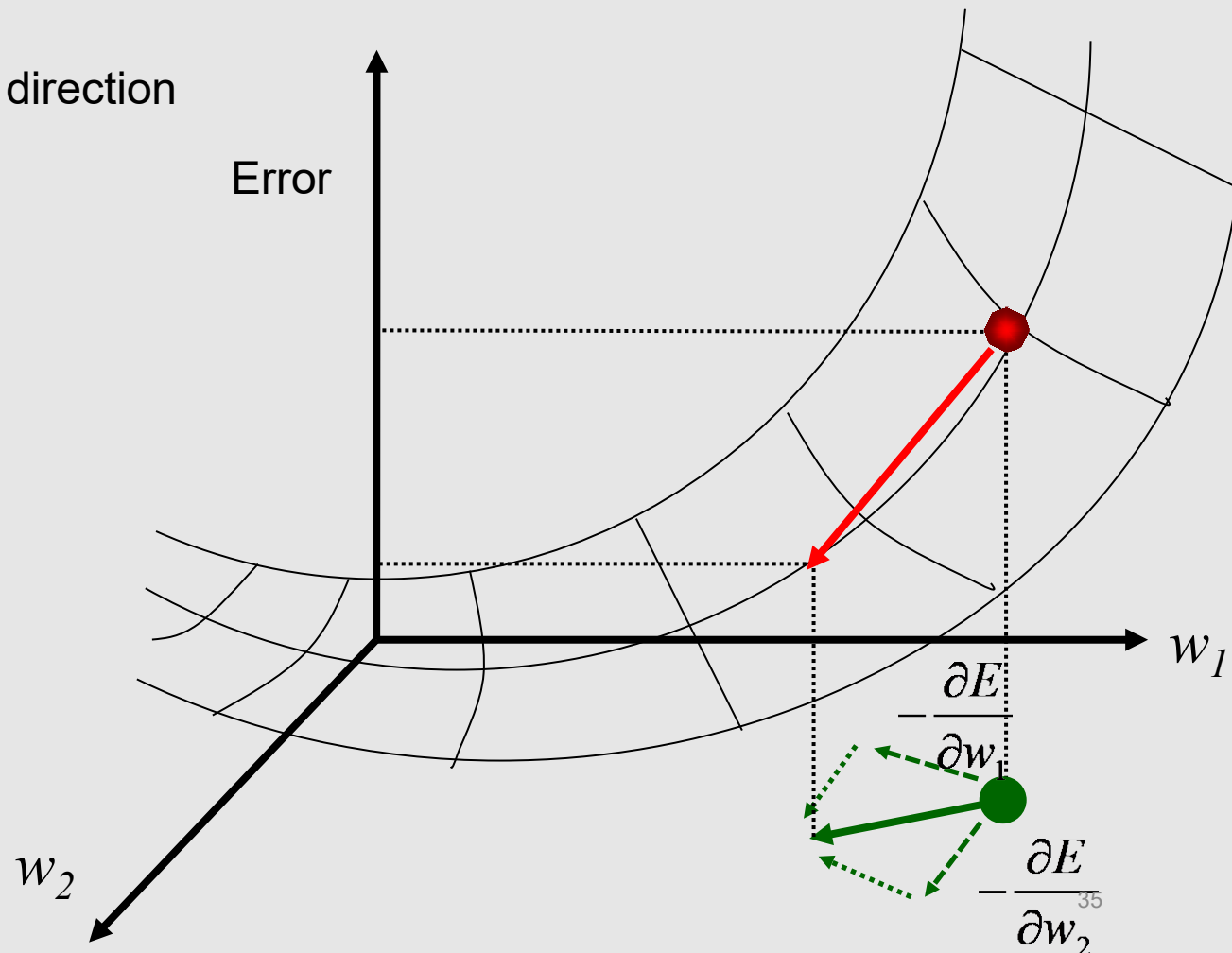

Batch neural network training



given: network structure and a training set $D = \{(x^{(1)}, y^{(1)}), \dots, (x^{(m)}, y^{(m)})\}$

initialize all weights in \mathbf{w} to small random numbers

until stopping criteria met do

initialize the error $E(\mathbf{w}) = 0$

for each $(\mathbf{x}^{(d)}, y^{(d)})$ in the training set

input $\mathbf{x}^{(d)}$ to the network and compute output $o^{(d)}$

increment the error $E(\mathbf{w}) = E(\mathbf{w}) + \frac{1}{2} (y^{(d)} - o^{(d)})^2$

calculate the gradient

$$\nabla E(\mathbf{w}) = \left[\frac{\partial E}{\partial w_0}, \frac{\partial E}{\partial w_1}, \dots, \frac{\partial E}{\partial w_n} \right]$$

update the weights

$$\mathbf{w} \leftarrow \mathbf{w} + \Delta \mathbf{w}, \quad \Delta \mathbf{w} = -\eta \nabla E(\mathbf{w})$$



Online vs. batch training

- Standard gradient descent (batch training): calculates error gradient for the entire training set, before taking a step in weight space
- *Stochastic gradient descent* (online training): calculates error gradient for a single instance, then takes a step in weight space
 - much faster convergence
 - less susceptible to local minima

Online neural network training (stochastic gradient descent)



given: network structure and a training set $D = \{(x^{(1)}, y^{(1)}), \dots, (x^{(m)}, y^{(m)})\}$

initialize all weights in \mathbf{w} to small random numbers

until stopping criteria met do

for each $(\mathbf{x}^{(d)}, y^{(d)})$ in the training set

input $\mathbf{x}^{(d)}$ to the network and compute output $o^{(d)}$

calculate the error $E^{(d)}(\mathbf{w}) = \frac{1}{2} (y^{(d)} - o^{(d)})^2$

calculate the gradient

$$\nabla E^{(d)}(\mathbf{w}) = \left[\frac{\partial E^{(d)}}{\partial w_0}, \frac{\partial E^{(d)}}{\partial w_1}, \dots, \frac{\partial E^{(d)}}{\partial w_n} \right]$$

update the weights

$$\mathbf{w} \leftarrow \mathbf{w} + \Delta \mathbf{w}, \quad \Delta \mathbf{w} = -\eta \nabla E^{(d)}(\mathbf{w})$$

Taking derivatives for one neuron



recall the chain rule from calculus

$$y = f(u)$$

$$u = g(x)$$

$$\frac{\partial y}{\partial x} = \frac{\partial y}{\partial u} \frac{\partial u}{\partial x}$$

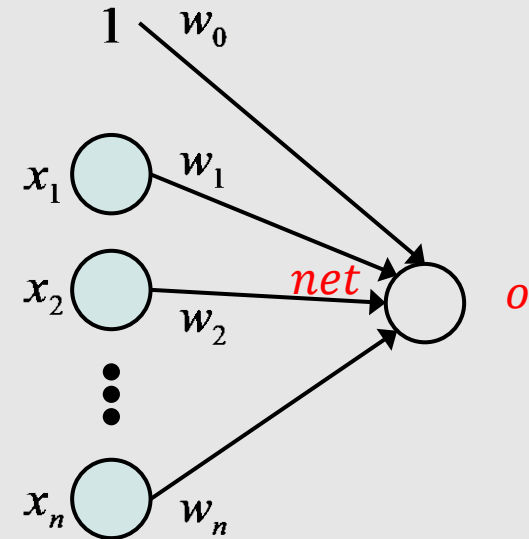

we'll make use of this as follows

$$\frac{\partial E}{\partial w_i} = \frac{\partial E}{\partial o} \frac{\partial o}{\partial net} \frac{\partial net}{\partial w_i}$$

$$net = w_0 + \sum_{i=1}^n w_i x_i$$



Gradient descent: simple case

Consider a simple case of a network with one linear output unit and no hidden units:

$$o^{(d)} = w_0 + \sum_{i=1}^n w_i x_i^{(d)}$$

let's learn w_i 's that minimize squared error

$$E(\mathbf{w}) = \frac{1}{2} \sum_{d \in D} (y^{(d)} - o^{(d)})^2$$

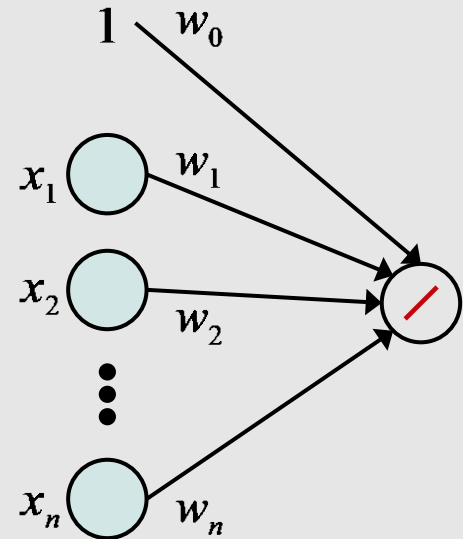

batch case

$$\frac{\partial E}{\partial w_i} = \frac{\partial}{\partial w_i} \frac{1}{2} \sum_{d \in D} (y^{(d)} - o^{(d)})^2$$

online case

$$\frac{\partial E^{(d)}}{\partial w_i} = \frac{\partial}{\partial w_i} \frac{1}{2} (y^{(d)} - o^{(d)})^2$$

Stochastic gradient descent: simple case

let's focus on the online case (stochastic gradient descent):

$$\begin{aligned}\frac{\partial E^{(d)}}{\partial w_i} &= \frac{\partial}{\partial w_i} \frac{1}{2} (y^{(d)} - o^{(d)})^2 \\ &= (y^{(d)} - o^{(d)}) \frac{\partial}{\partial w_i} (y^{(d)} - o^{(d)}) \\ &= (y^{(d)} - o^{(d)}) \left(-\frac{\partial o^{(d)}}{\partial w_i} \right) \\ &= -(y^{(d)} - o^{(d)}) \frac{\partial o^{(d)}}{\partial net^{(d)}} \frac{\partial net^{(d)}}{\partial w_i} = -(y^{(d)} - o^{(d)}) \frac{\partial net^{(d)}}{\partial w_i} \\ &= -(y^{(d)} - o^{(d)}) x_i^{(d)}\end{aligned}$$



Gradient descent with a sigmoid

Now let's consider the case in which we have a sigmoid output unit and no hidden units:

$$net^{(d)} = w_0 + \sum_{i=1}^n w_i x_i^{(d)}$$

$$o^{(d)} = \frac{1}{1 + e^{-net^{(d)}}}$$

useful property:

$$\frac{\partial o^{(d)}}{\partial net^{(d)}} = o^{(d)}(1 - o^{(d)})$$

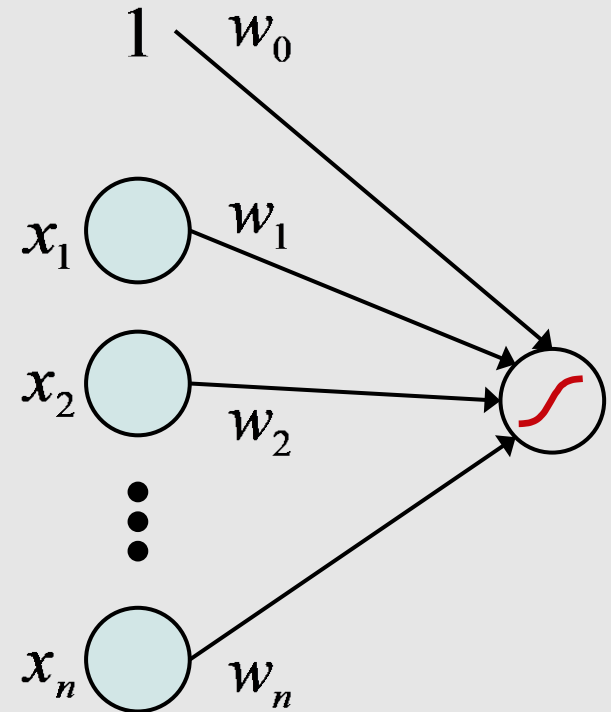

Stochastic GD with sigmoid output unit



$$\begin{aligned}\frac{\partial E^{(d)}}{\partial w_i} &= \frac{\partial}{\partial w_i} \frac{1}{2} (y^{(d)} - o^{(d)})^2 \\ &= (y^{(d)} - o^{(d)}) \frac{\partial}{\partial w_i} (y^{(d)} - o^{(d)}) \\ &= (y^{(d)} - o^{(d)}) \left(-\frac{\partial o^{(d)}}{\partial w_i} \right) \\ &= -\left(y^{(d)} - o^{(d)} \right) \frac{\partial o^{(d)}}{\partial net^{(d)}} \frac{\partial net^{(d)}}{\partial w_i} \\ &= -\left(y^{(d)} - o^{(d)} \right) o^{(d)} (1 - o^{(d)}) \frac{\partial net^{(d)}}{\partial w_i} \\ &= -\left(y^{(d)} - o^{(d)} \right) o^{(d)} (1 - o^{(d)}) x_i^{(d)}\end{aligned}$$

Backpropagation



- now we've covered how to do gradient descent for single neurons (i.e., single-layer networks) with
 - linear output units
 - sigmoid output units
- how can we calculate $\frac{\partial E}{\partial w_i}$ for every weight in a multilayer network?
 - backpropagate errors from the output units to the hidden units

Backpropagation notation



let's consider the online case, but drop the (d) superscripts for simplicity
let's consider hidden and output units have sigmoid activation

we'll use

- subscripts on y , o , net to indicate which unit they refer to
- subscripts to indicate the unit a weight emanates from and goes to

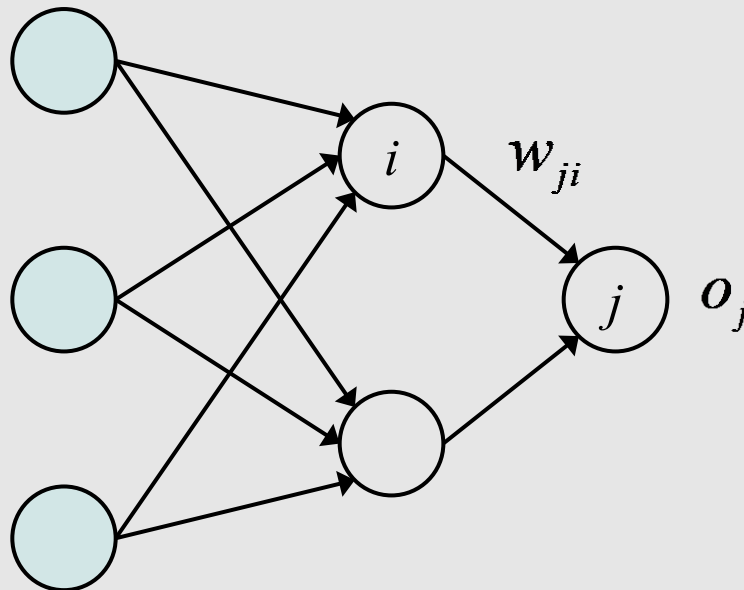

Backpropagation



each weight is changed by

$$\begin{aligned}\Delta w_{ji} &= -\eta \frac{\partial E}{\partial w_{ji}} \\ &= -\eta \frac{\partial E}{\partial net_j} \frac{\partial net_j}{\partial w_{ji}} \\ &= \eta \delta_j o_i\end{aligned}$$

x_i if i is an input unit

where $\delta_j = -\frac{\partial E}{\partial net_j}$

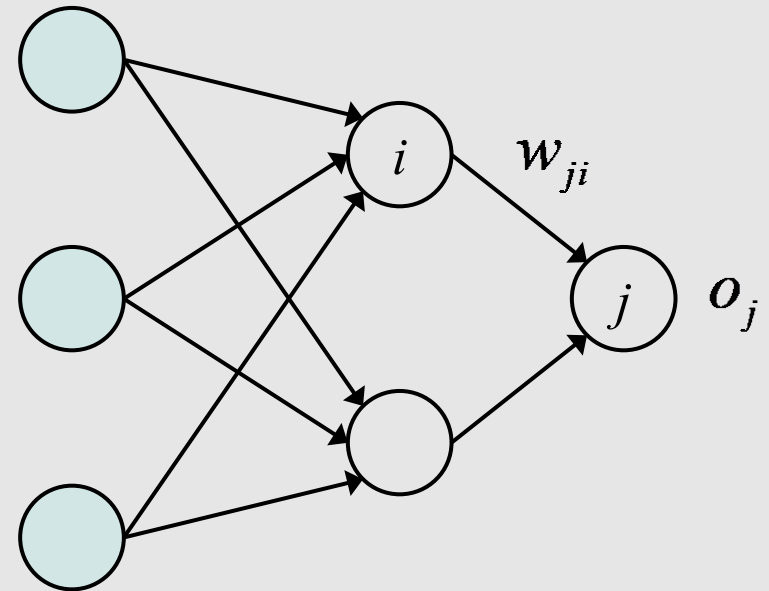

Backpropagation



each weight is changed by $\Delta w_{ji} = \eta \delta_j o_i$

$$\text{where } \delta_j = -\frac{\partial E}{\partial \text{net}_j}$$

Case 1: if j is an output sigmoid unit

$$\delta_j = \underbrace{o_j(1 - o_j)}_{\text{same as single neuron with sigmoid output}} (y_j - o_j)$$

same as single neuron with sigmoid output

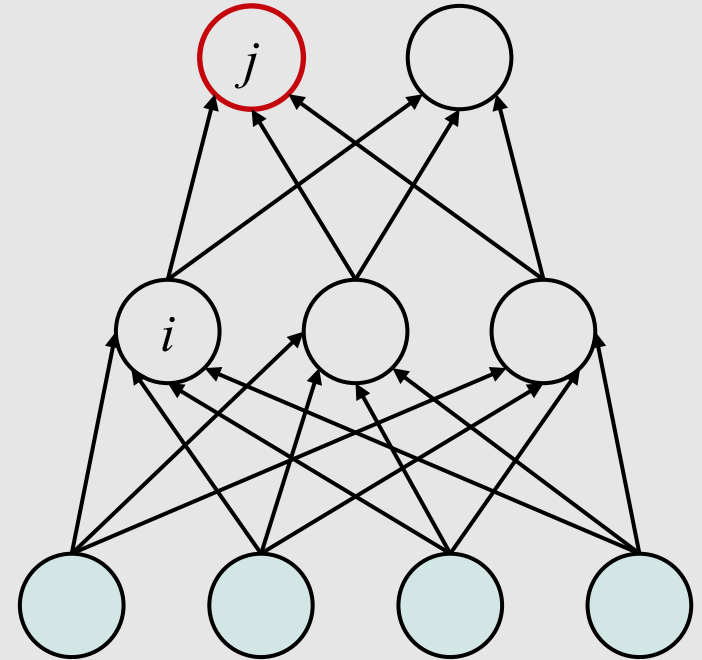

Backpropagation



each weight is changed by $\Delta w_{ji} = \eta \delta_j o_i$

$$\text{where } \delta_j = -\frac{\partial E}{\partial \text{net}_j}$$

Case 2: if j is a hidden unit

$$\delta_j = -\underbrace{\sum_k}_{\text{sum over all downstream neurons } k} \frac{\partial E}{\partial \text{net}_k} \frac{\partial \text{net}_k}{\partial o_j} \frac{\partial o_j}{\partial \text{net}_j} = o_j(1 - o_j) \sum_k \delta_k w_{kj}$$

sum over all downstream neurons k ,
sum of backpropagated contributions to error

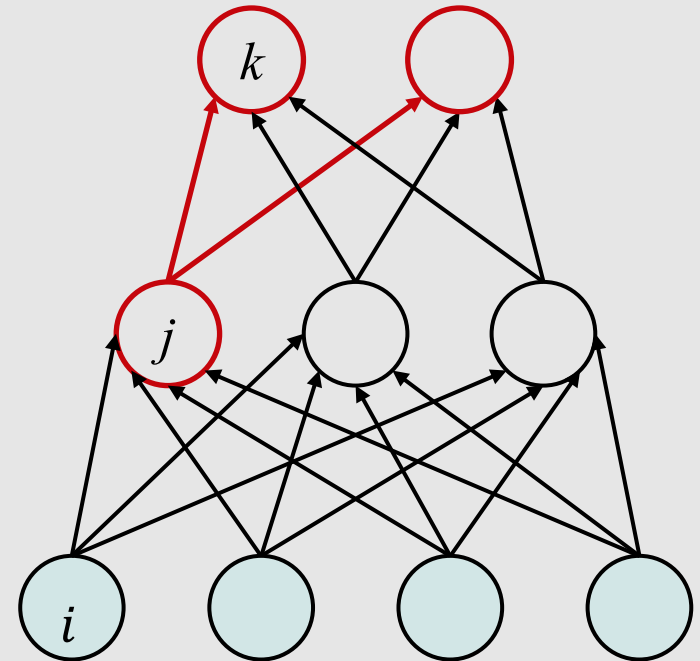

Backpropagation illustrated



1. calculate error of output units

$$\delta_j = o_j(1 - o_j)(y_j - o_j)$$

2. determine updates for weights going to output units

$$\Delta w_{ji} = \eta \delta_j o_i$$

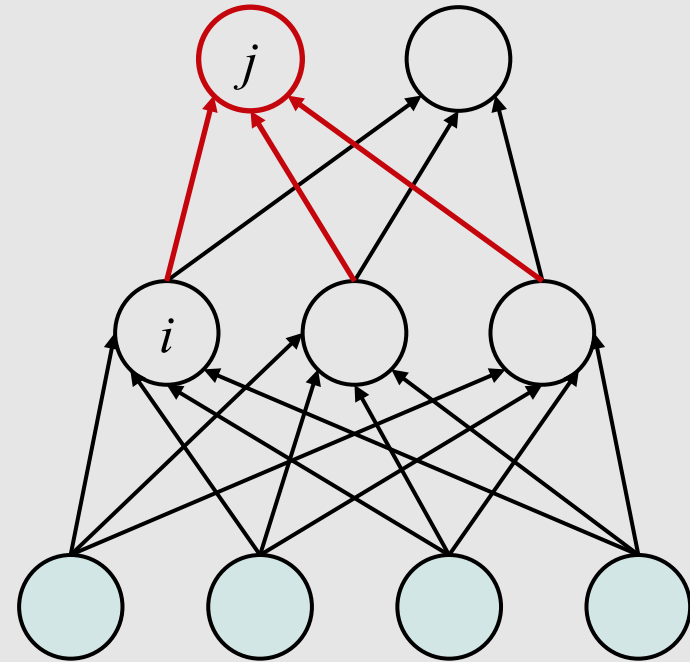
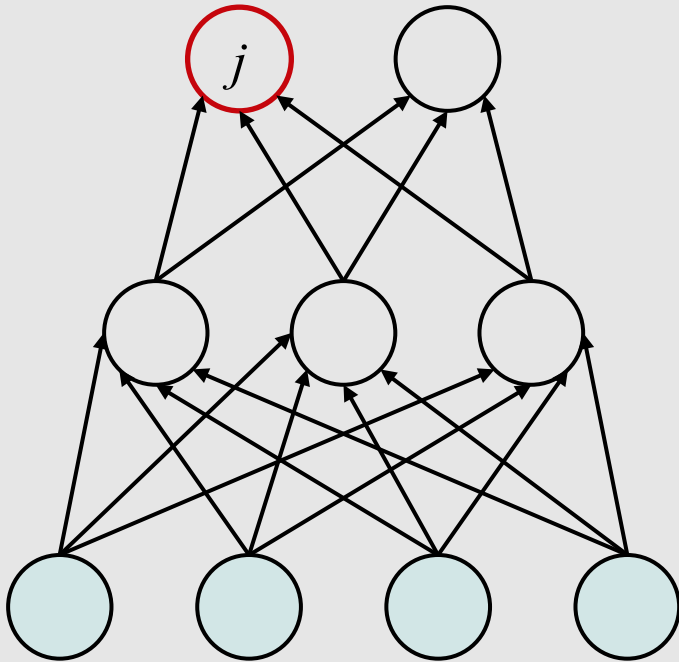

Backpropagation illustrated



3. calculate error for hidden units

$$\delta_j = o_j(1 - o_j) \sum_k \delta_k w_{kj}$$

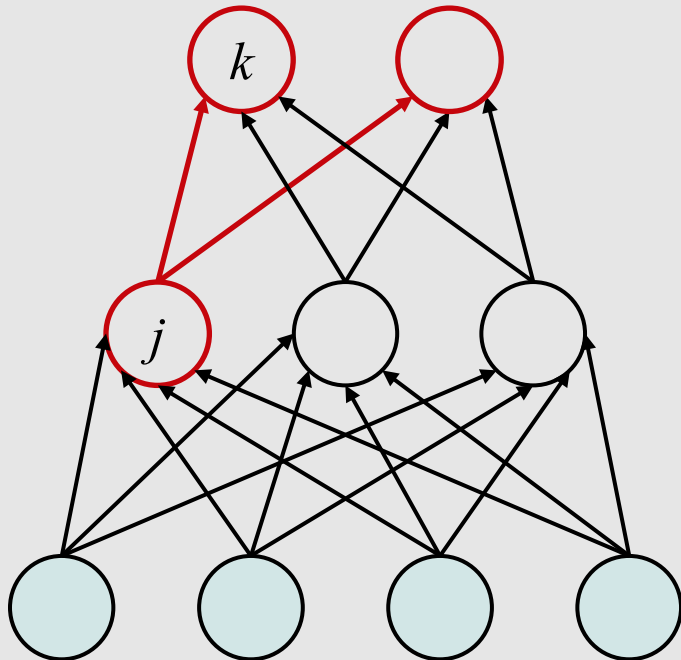

4. determine updates for weights to hidden units using hidden-unit errors

$$\Delta w_{ji} = \eta \delta_j o_i$$

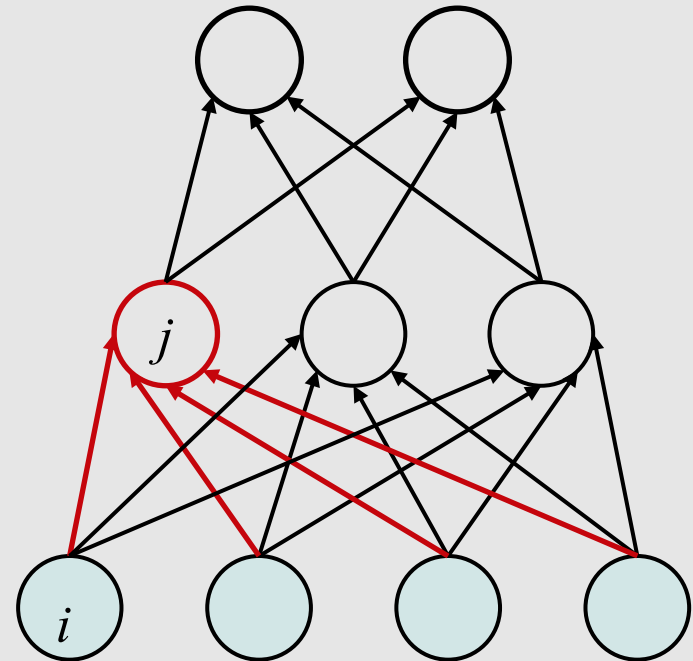

An aerial photograph of a city waterfront at sunset. The sun is low on the horizon, casting a golden glow over the scene. The water is dark blue with many sailboats scattered across it. The city buildings are visible on the left side, and a large body of water occupies the right side. The overall atmosphere is peaceful and scenic.

More Illustration of Backpropagation



Learning in neural network

- Again we will minimize the error (K outputs):

$$E = \frac{1}{2} \sum_{x \in D} E_x, \quad E_x = \|y - a\|^2 = \sum_{c=1}^K (a_c - y_c)^2$$

- x : one training point in the training set D
- a_c : the c -th output for the training point x
- y_c : the c -th element of the label indicator vector for x

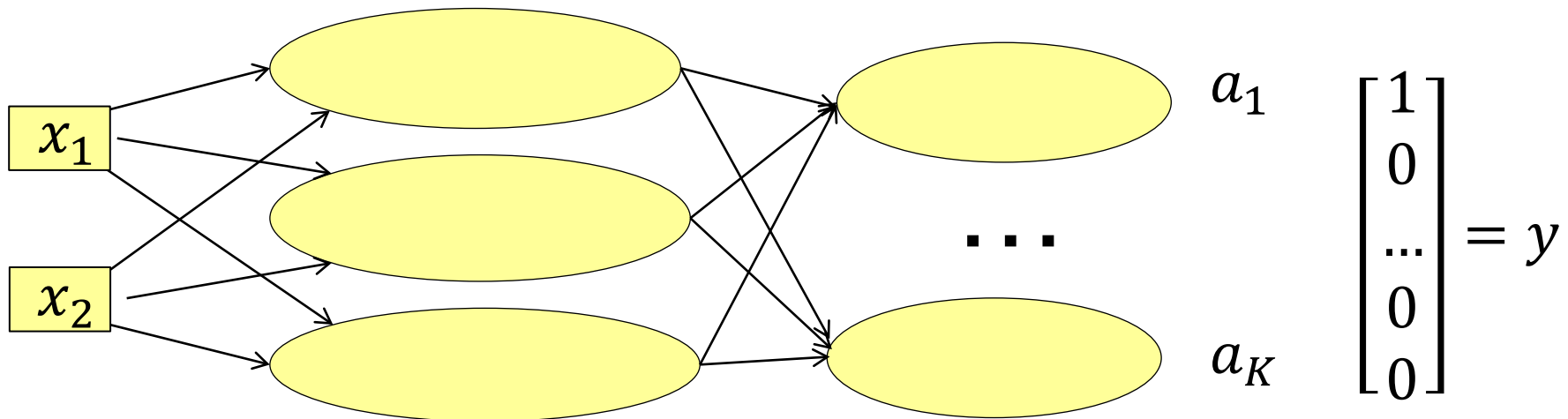

Learning in neural network

- Again we will minimize the error (K outputs):

$$E = \frac{1}{2} \sum_{x \in D} E_x, \quad E_x = \|y - a\|^2 = \sum_{c=1}^K (a_c - y_c)^2$$

- x : one training point in the training set D
- a_c : the c -th output for the training point x
- y_c : the c -th element of the label indicator vector for x
- Our variables are **all the weights w on all the edges**
 - Apparent difficulty: we don't know the 'correct' output of hidden units

Learning in neural network

- Again we will minimize the error (K outputs):

$$E = \frac{1}{2} \sum_{x \in D} E_x, \quad E_x = \|y - a\|^2 = \sum_{c=1}^K (a_c - y_c)^2$$

- x : one training point in the training set D
- a_c : the c -th output for the training point x
- y_c : the c -th element of the label indicator vector for x
- Our variables are **all the weights w on all the edges**
 - Apparent difficulty: we don't know the 'correct' output of hidden units
 - It turns out to be OK: we can still do gradient descent. The trick you need is the **chain rule**
 - The algorithm is known as **back-propagation**

Gradient (on one data point)

Layer (1)

Layer (2)

Layer (3)

Layer (4)

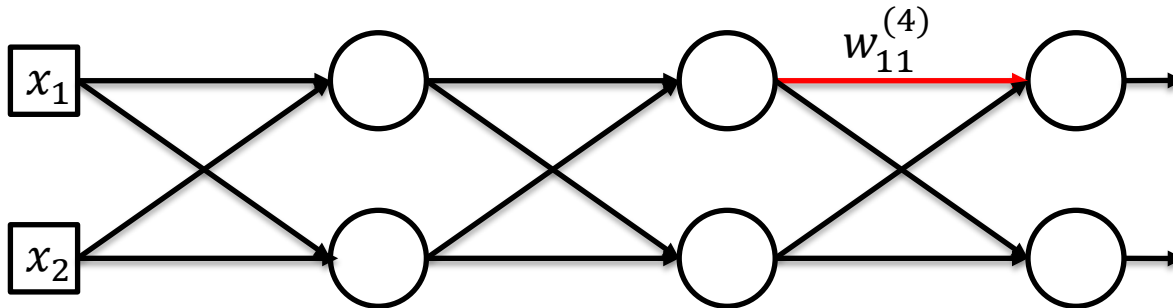

E_x

want to compute $\frac{\partial E_x}{\partial w_{11}^{(4)}}$

Gradient (on one data point)

Layer (1)

Layer (2)

Layer (3)

Layer (4)

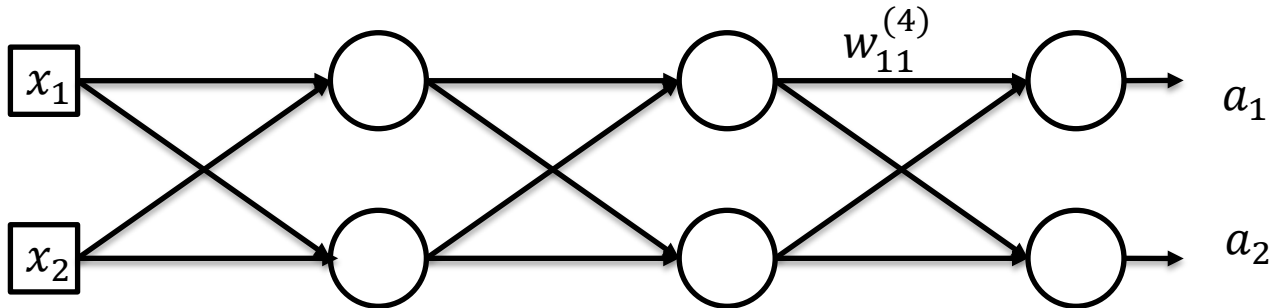

$$E_x = \|y - a\|^2$$

$$a_1 \xrightarrow{\|y - a\|^2} E_x$$

Gradient (on one data point)

Layer (1)

Layer (2)

Layer (3)

Layer (4)

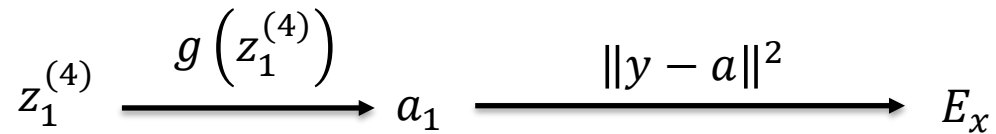
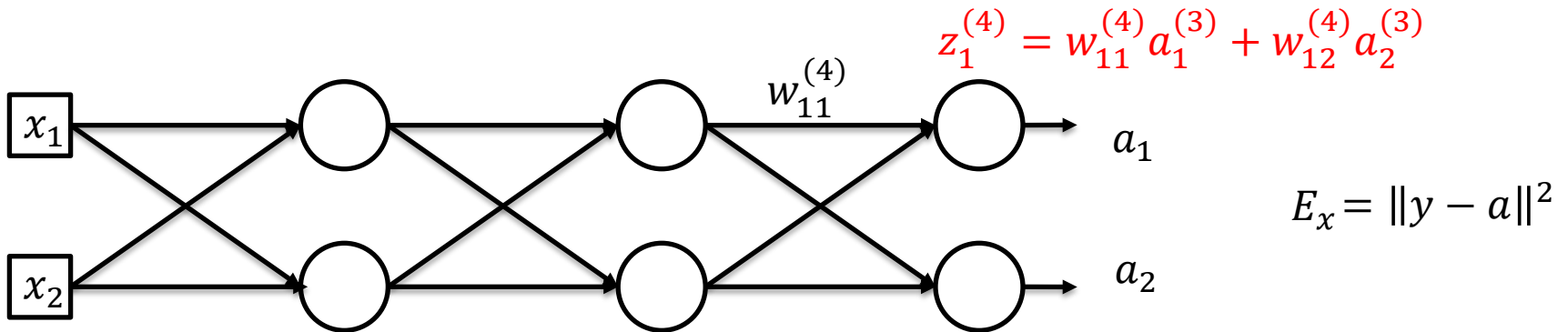

Gradient (on one data point)

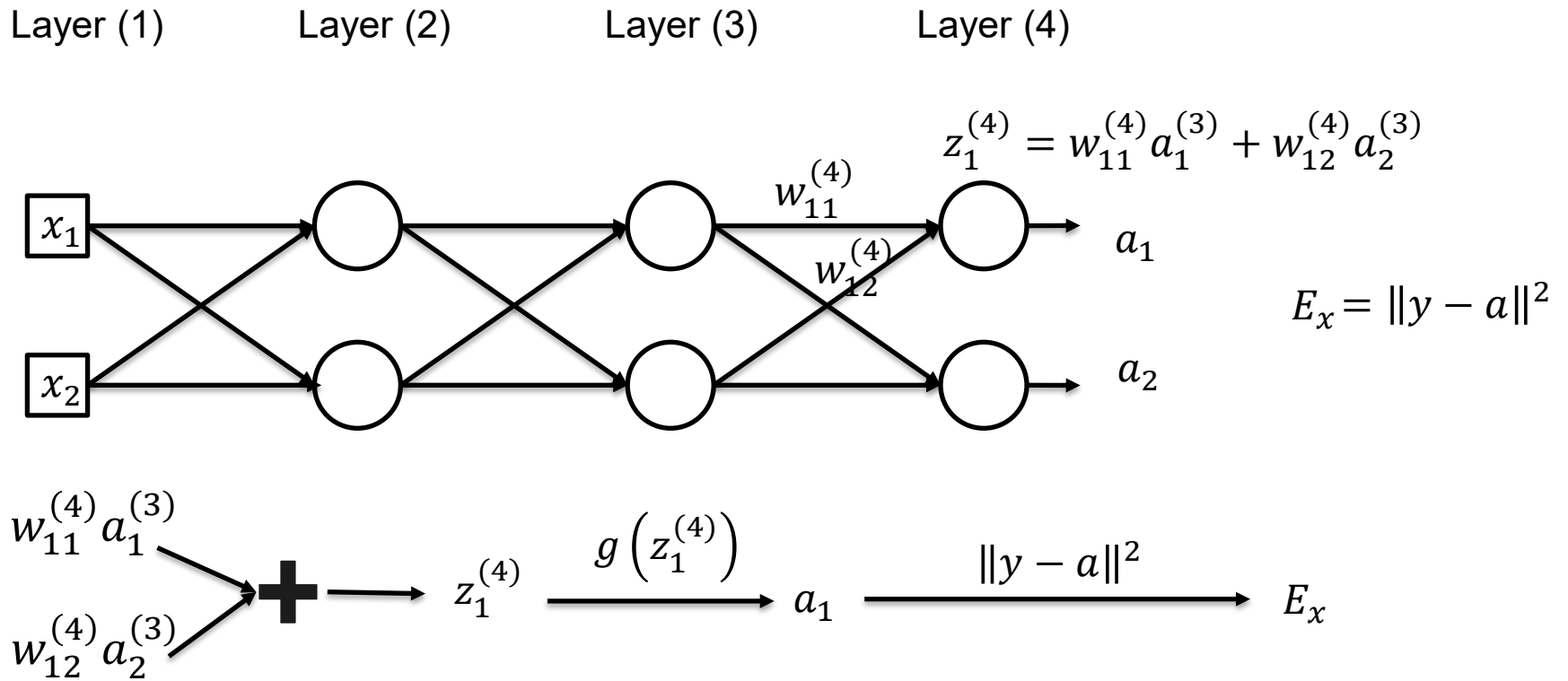

Gradient (on one data point)

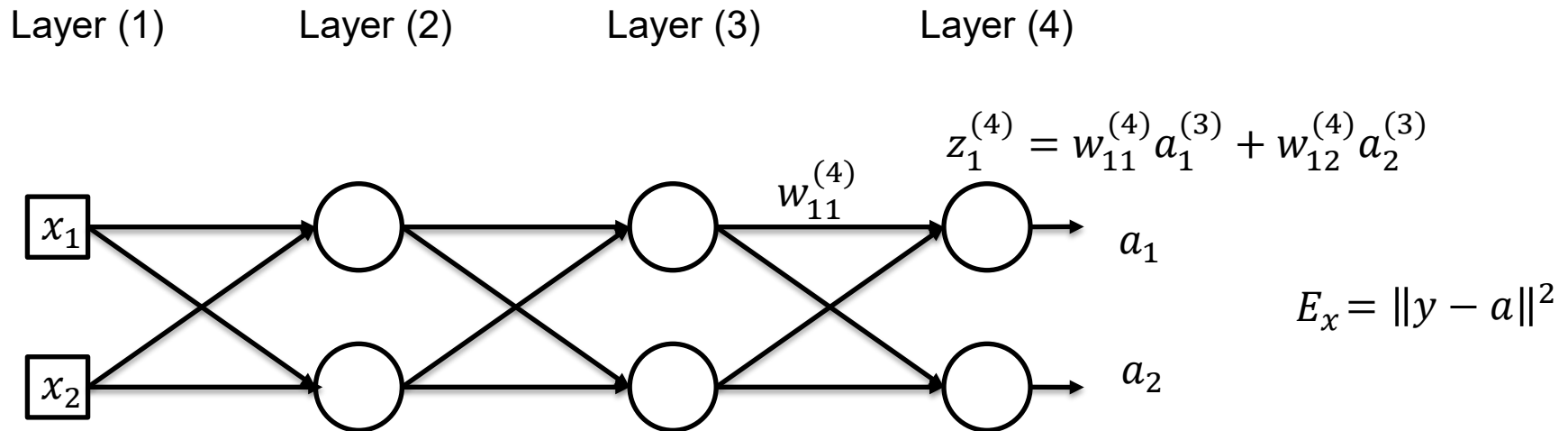

$$\begin{array}{c}
 w_{11}^{(4)} a_1^{(3)} \\
 w_{12}^{(4)} a_2^{(3)}
 \end{array}
 \rightarrow \text{+} \rightarrow z_1^{(4)} \xrightarrow{g(z_1^{(4)})} a_1 \xrightarrow{\|y - a\|^2} E_x$$

$$\frac{\partial a_1}{\partial z_1^{(4)}} = g'(z_1^{(4)}) \qquad \frac{\partial E_x}{\partial a_1} = 2(a_1 - y_1)$$

By Chain Rule:

$$\frac{\partial E_x}{\partial w_{11}^{(4)}} = \frac{\partial E_x}{\partial a_1} \frac{\partial a_1}{\partial z_1^{(4)}} \frac{\partial z_1^{(4)}}{\partial w_{11}^{(4)}}$$

Gradient (on one data point)

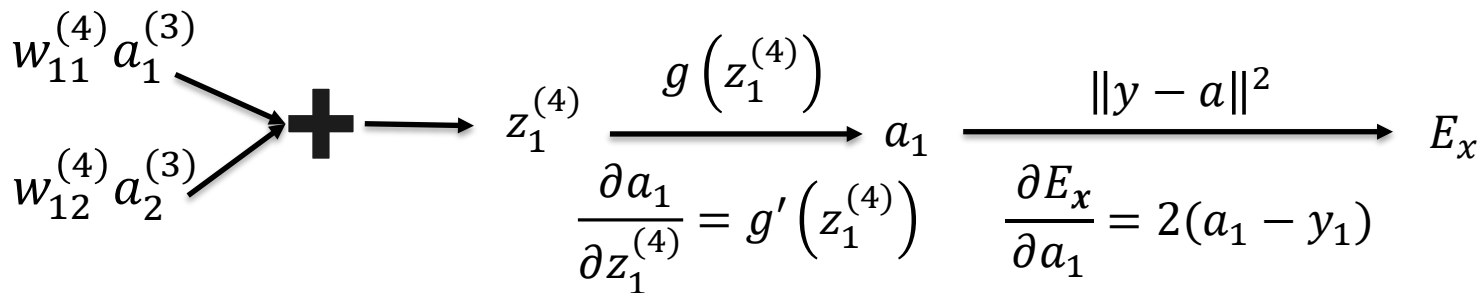
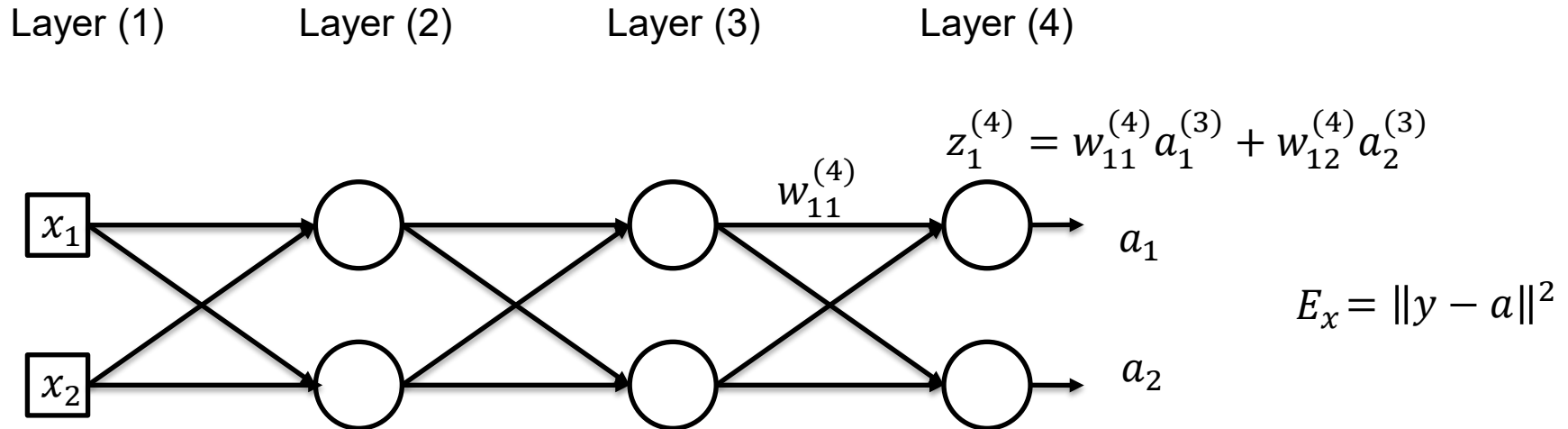

By Chain Rule:

$$\frac{\partial E_x}{\partial w_{11}^{(4)}} = 2(a_1 - y_1) g'(z_1^{(4)}) \frac{\partial z_1^{(4)}}{\partial w_{11}^{(4)}}$$

Gradient (on one data point)

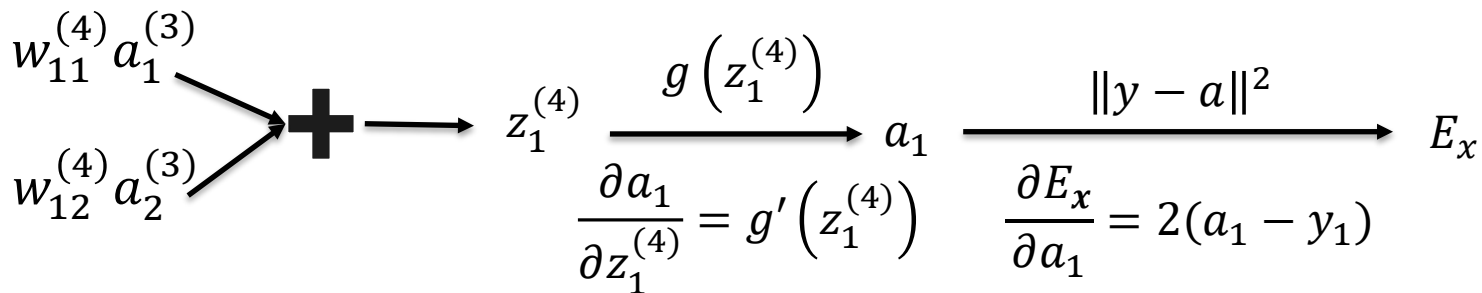
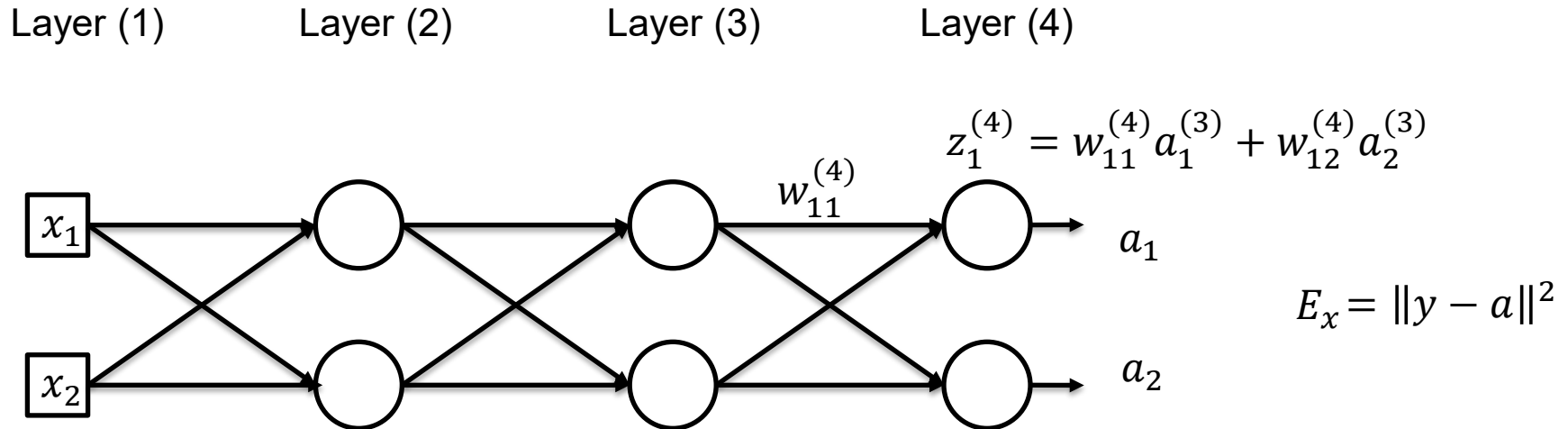

By Chain Rule:
$$\frac{\partial E_x}{\partial w_{11}^{(4)}} = 2(a_1 - y_1) g'(z_1^{(4)}) a_1^{(3)}$$

Gradient (on one data point)

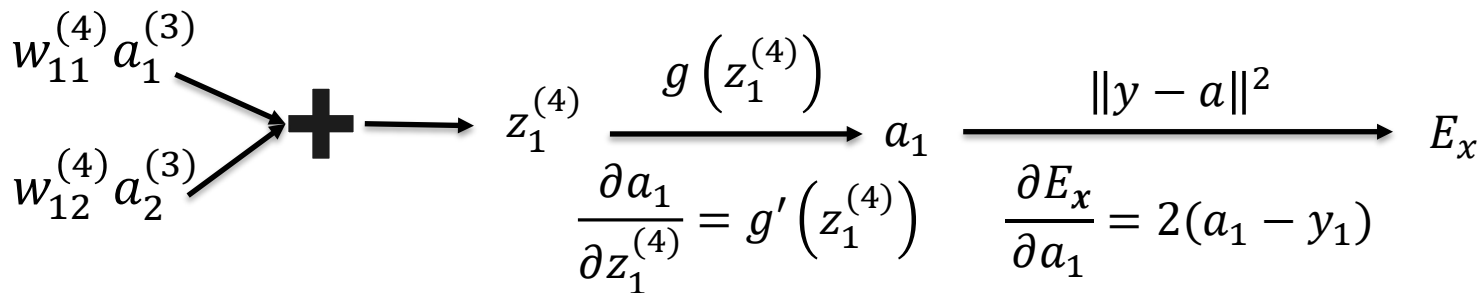
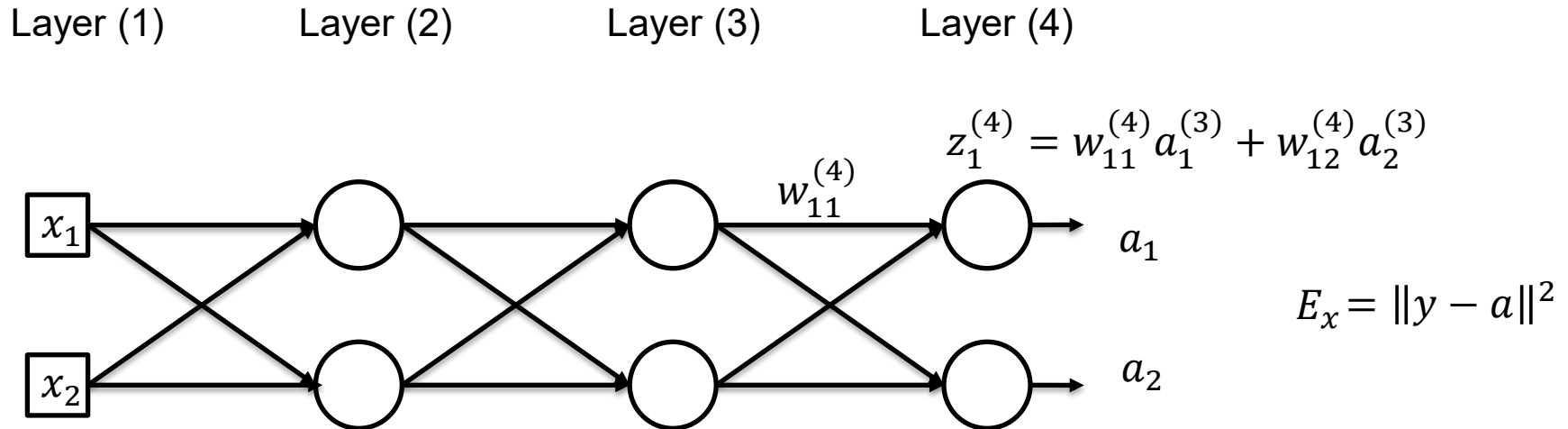

By Chain Rule:

$$\frac{\partial E_x}{\partial w_{11}^{(4)}} = 2(a_1 - y_1) g(z_1^{(4)}) \left(1 - g(z_1^{(4)})\right) a_1^{(3)}$$

Gradient (on one data point)

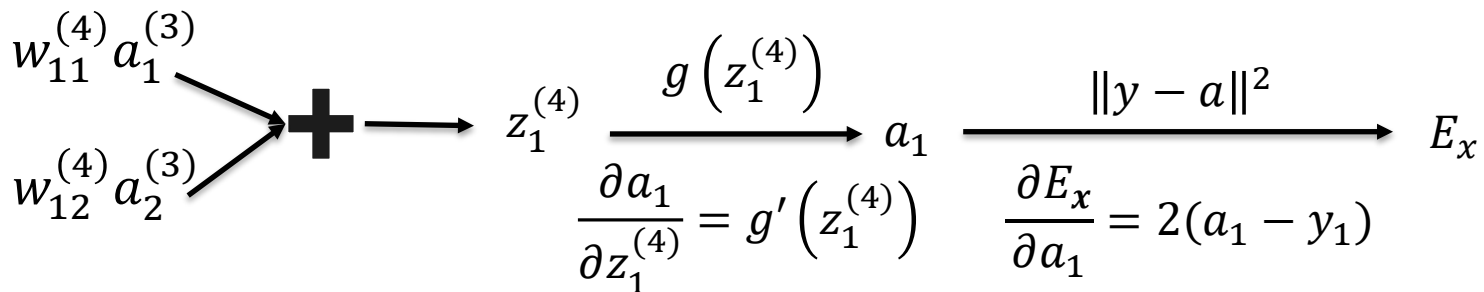
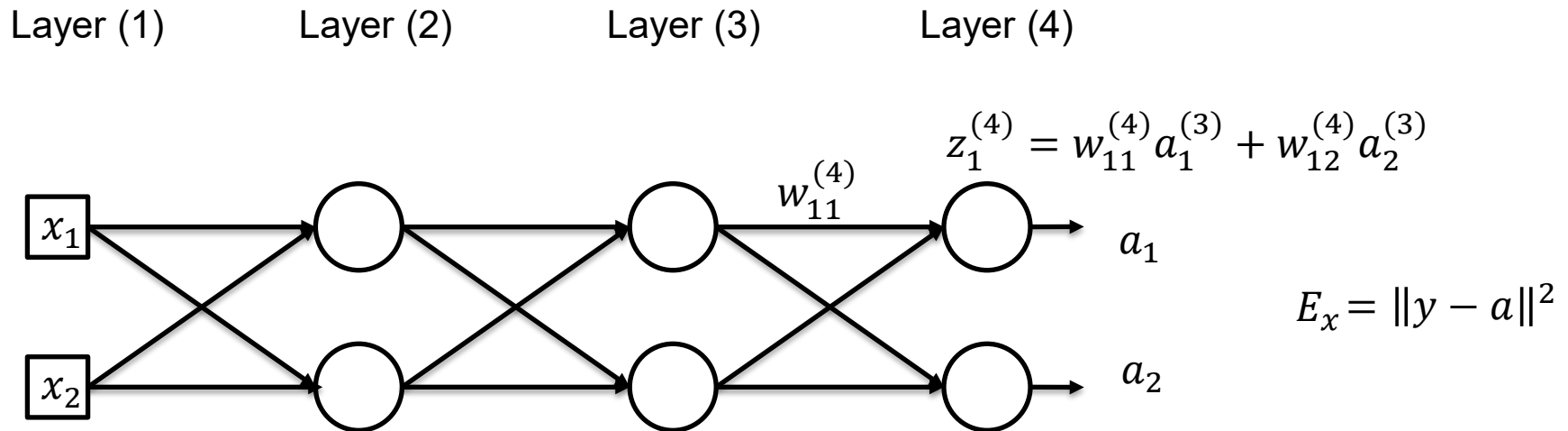

By Chain Rule:
$$\frac{\partial E_x}{\partial w_{11}^{(4)}} = 2(a_1 - y_1) a_1 (1 - a_1) a_1^{(3)}$$

Gradient (on one data point)

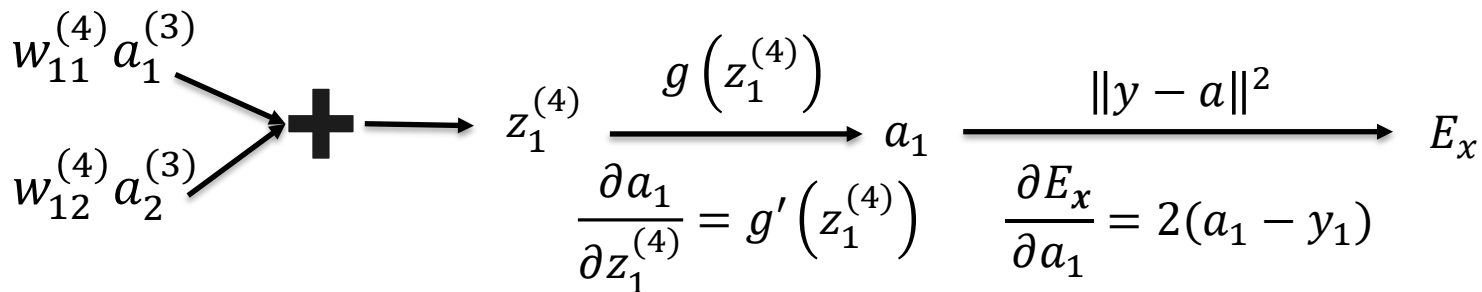
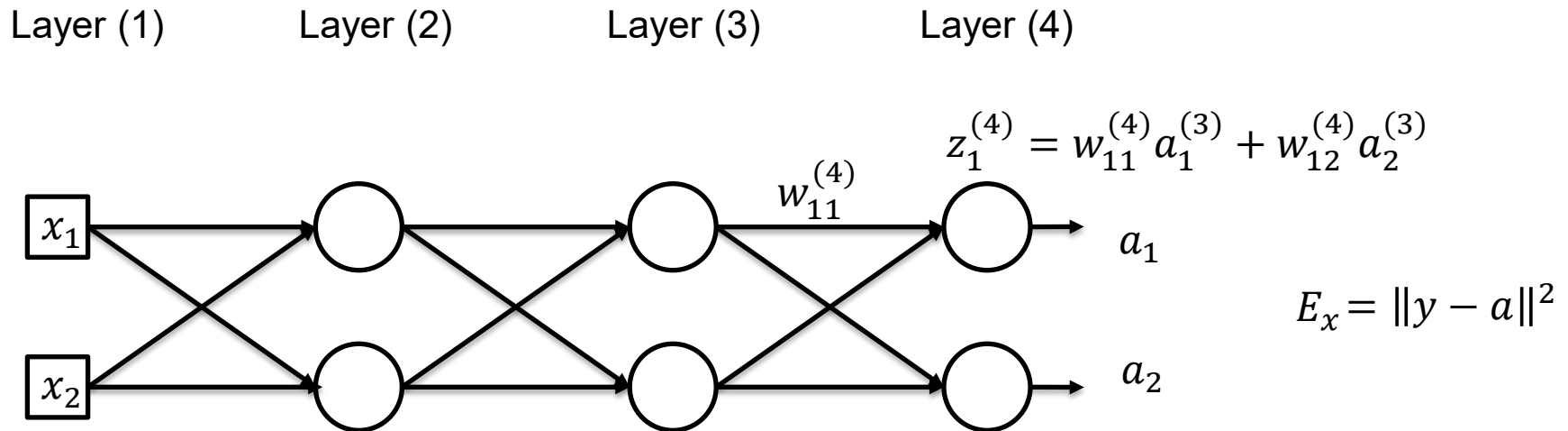

By Chain Rule:
$$\frac{\partial E_x}{\partial w_{11}^{(4)}} = 2(a_1 - y_1) a_1 (1 - a_1) a_1^{(3)}$$

Can be computed by network activation

Backpropagation

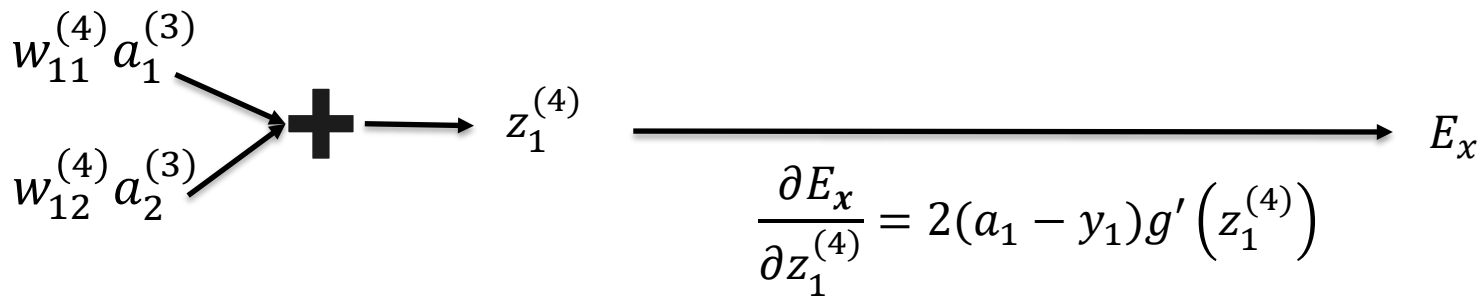
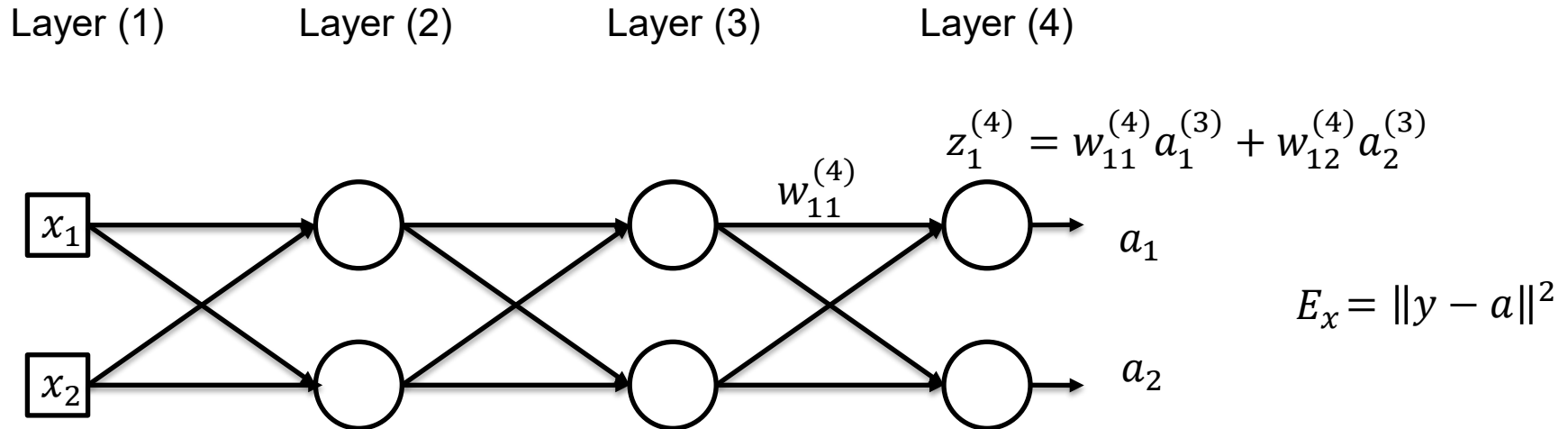

By Chain Rule:
$$\frac{\partial E_x}{\partial w_{11}^{(4)}} = 2(a_1 - y_1)a_1(1 - a_1)a_1^{(3)}$$

Backpropagation

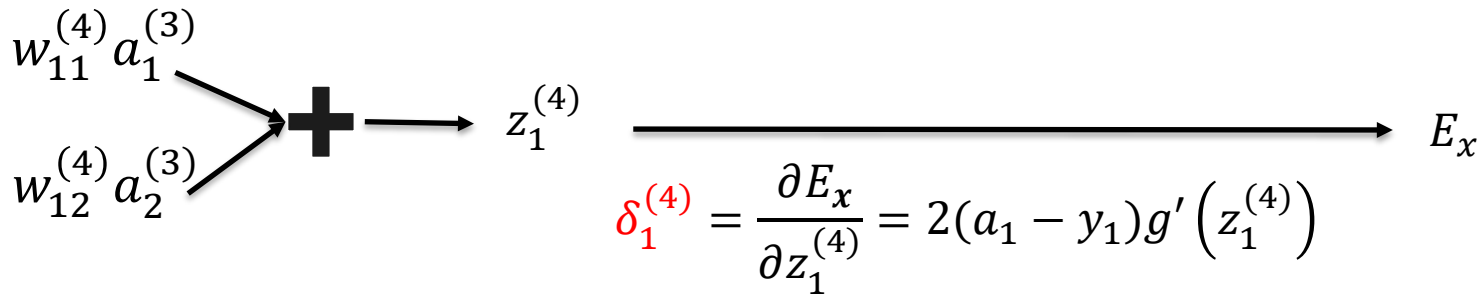
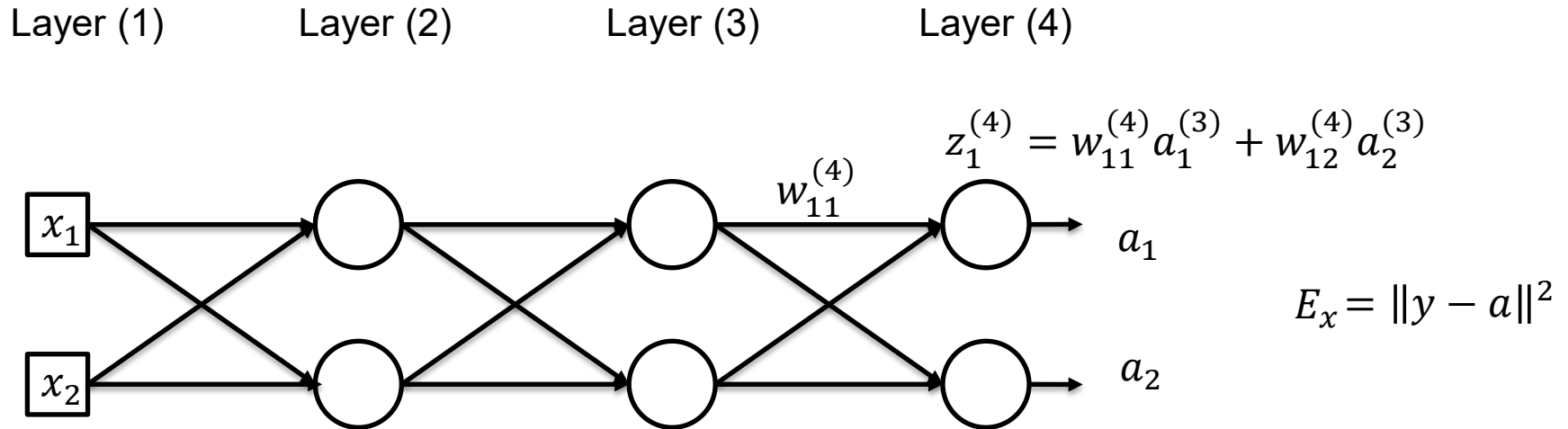

By Chain Rule: $\frac{\partial E_x}{\partial w_{11}^{(4)}} = 2(a_1 - y_1) a_1 (1 - a_1) a_1^{(3)}$

Backpropagation

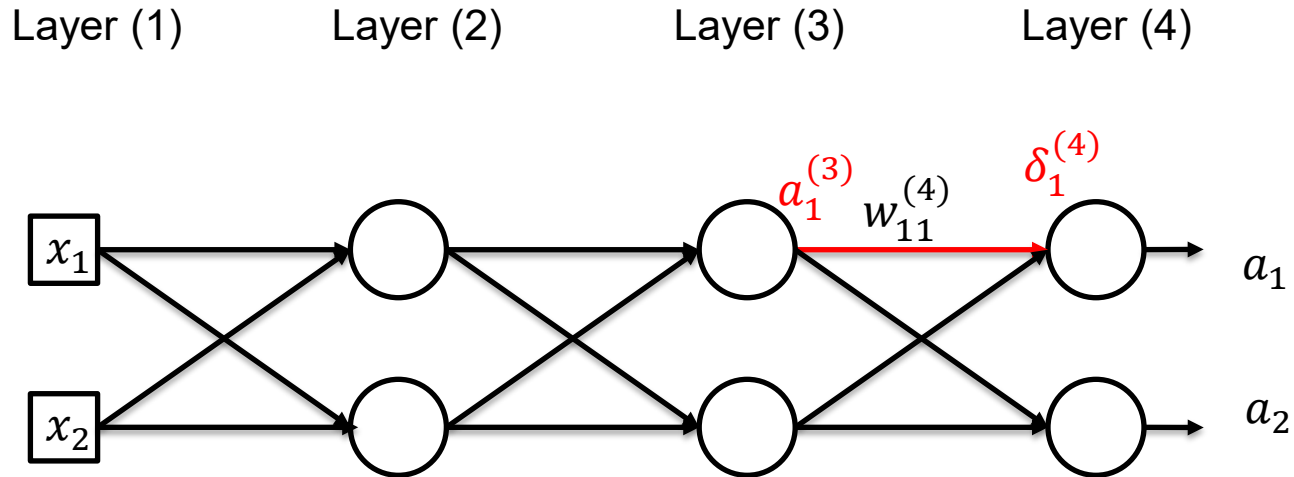

$$E_x = \|y - a\|^2$$

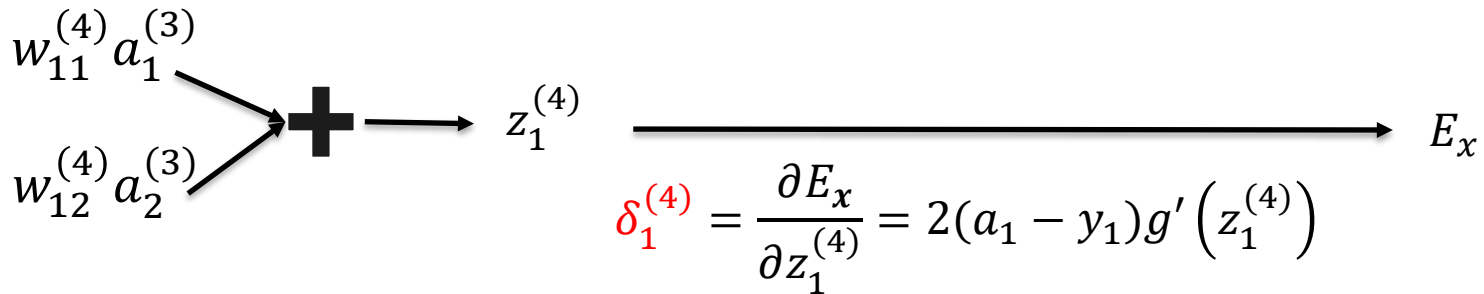

By Chain Rule:

$$\frac{\partial E_x}{\partial w_{11}^{(4)}} = \delta_1^{(4)} a_1^{(3)}$$

Backpropagation

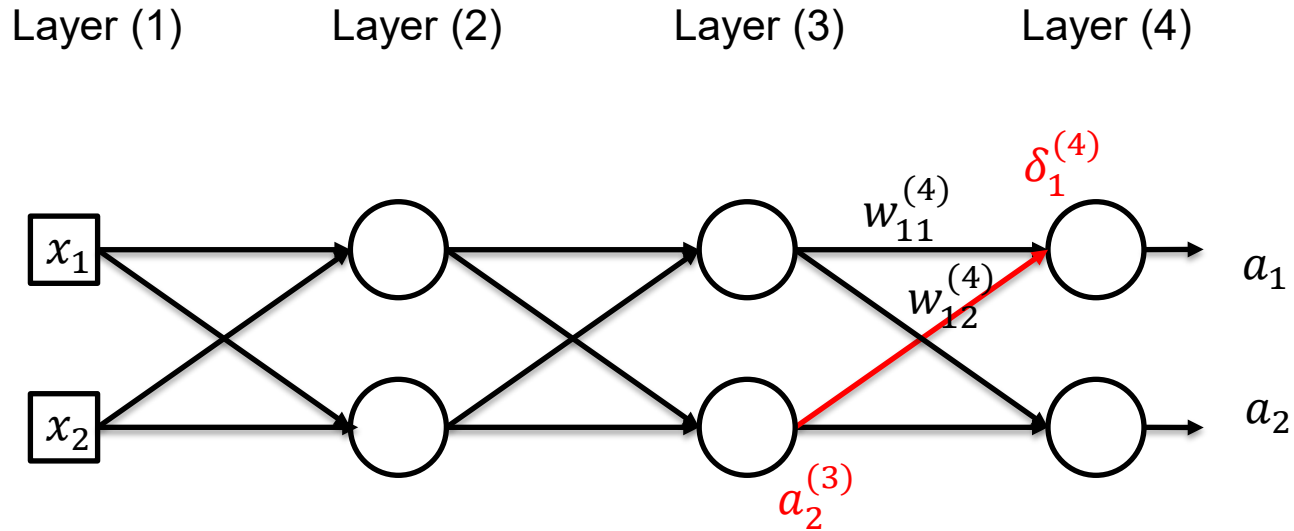

$$E_x = \|y - a\|^2$$

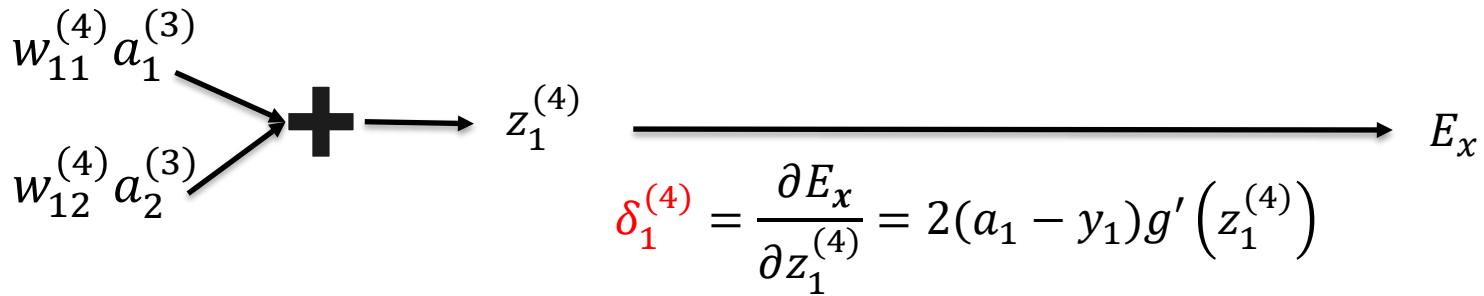

By Chain Rule: $\frac{\partial E_x}{\partial w_{11}^{(4)}} = \delta_1^{(4)} a_1^{(3)}$ $\frac{\partial E_x}{\partial w_{12}^{(4)}} = \delta_1^{(4)} a_2^{(3)}$

Backpropagation

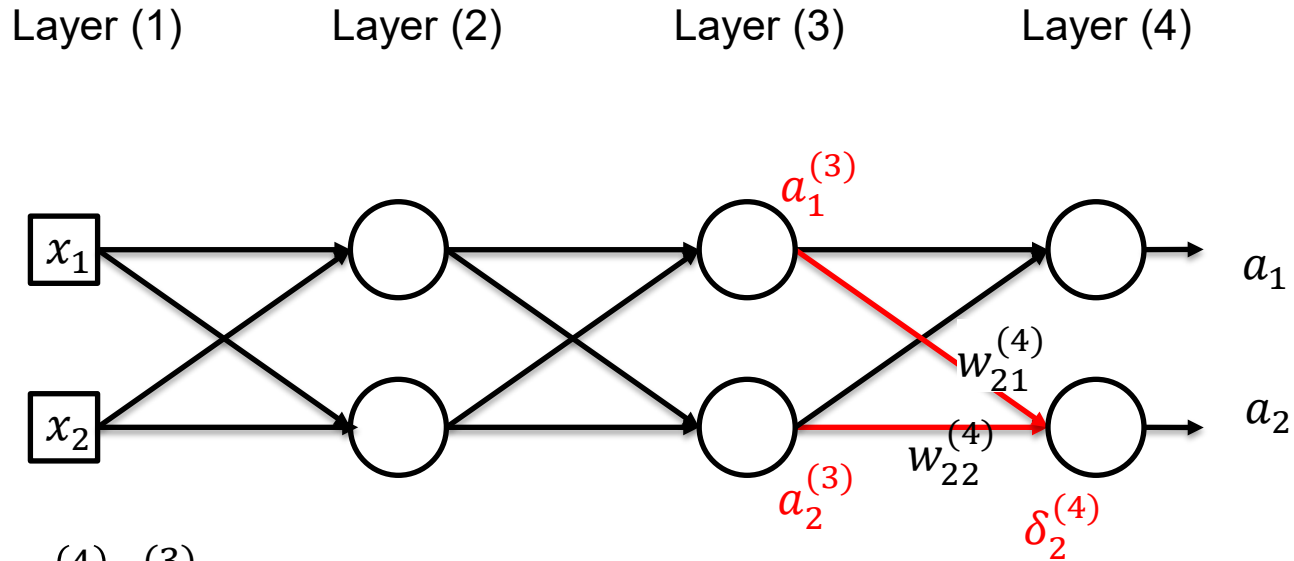

$$E_x = \|y - a\|^2$$

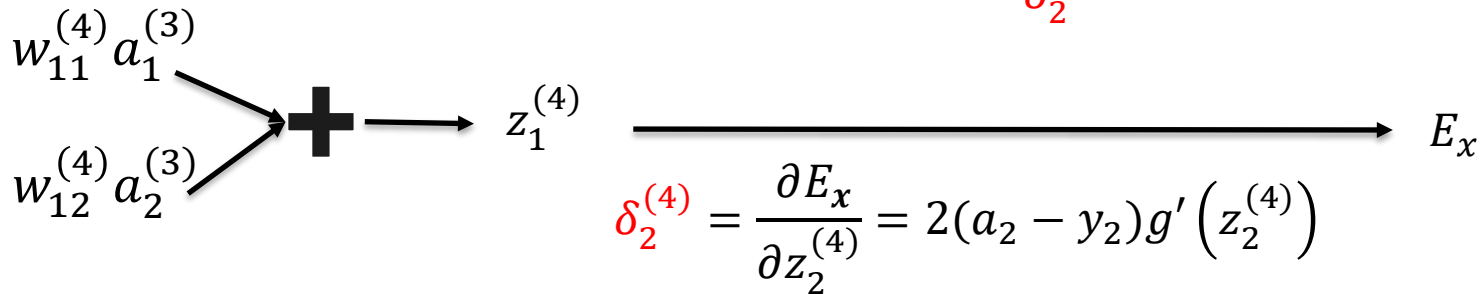

By Chain Rule:

$$\frac{\partial E_x}{\partial w_{21}^{(4)}} = \delta_2^{(4)} a_1^{(3)}, \quad \frac{\partial E_x}{\partial w_{22}^{(4)}} = \delta_2^{(4)} a_2^{(3)}$$

Backpropagation

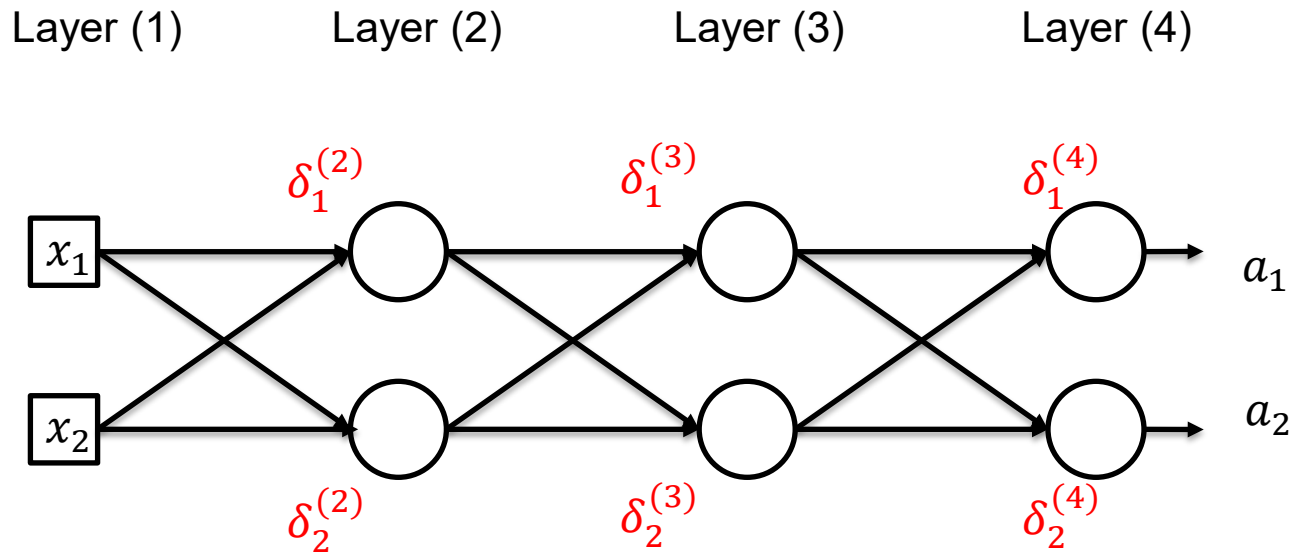

$$E_x = \|y - a\|^2$$

Thus, for any weight in the network:

$$\frac{\partial E_x}{\partial w_{jk}^{(l)}} = \delta_j^{(l)} a_k^{(l-1)}$$

$\delta_j^{(l)}$: δ of j^{th} neuron in Layer l

$a_k^{(l-1)}$: Activation of k^{th} neuron in Layer $l - 1$

$w_{jk}^{(l)}$: Weight from k^{th} neuron in Layer $l - 1$ to j^{th} neuron in Layer l

Exercise

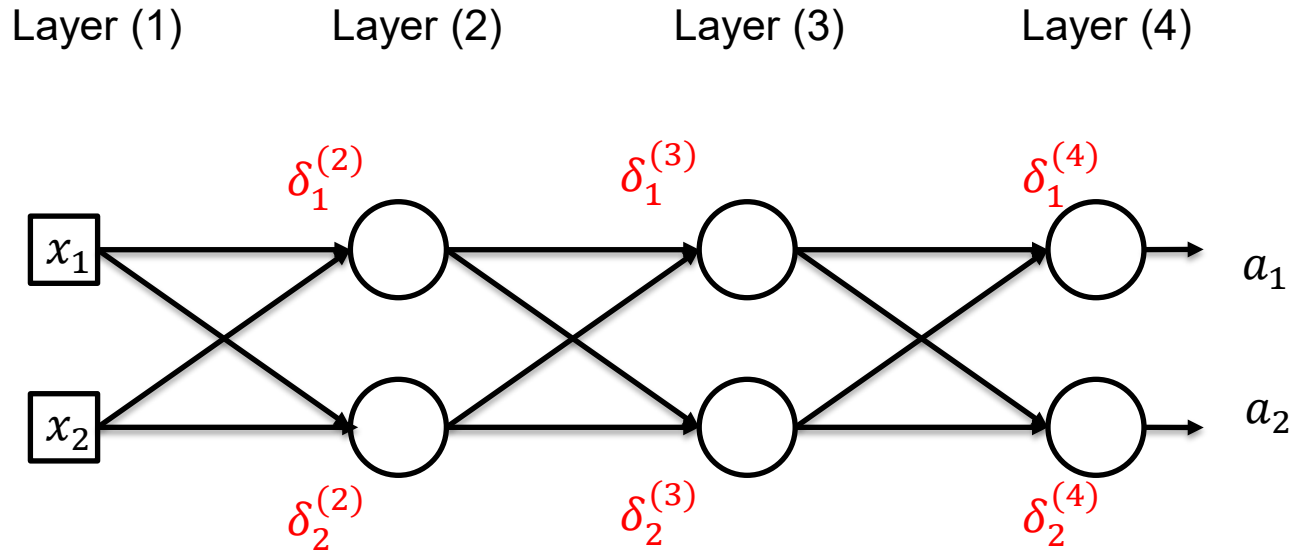

$$E_x = \|y - a\|^2$$

Show that for any bias in the network:

$$\frac{\partial E_x}{\partial b_j^{(l)}} = \delta_j^{(l)}$$

$\delta_j^{(l)}$: δ of j^{th} neuron in Layer l

$b_j^{(l)}$: bias for the j^{th} neuron in Layer l , i.e., $z_j^{(l)} = \sum_k w_{jk}^{(l)} a_k^{(l-1)} + b_j^{(l)}$

Backpropagation of δ

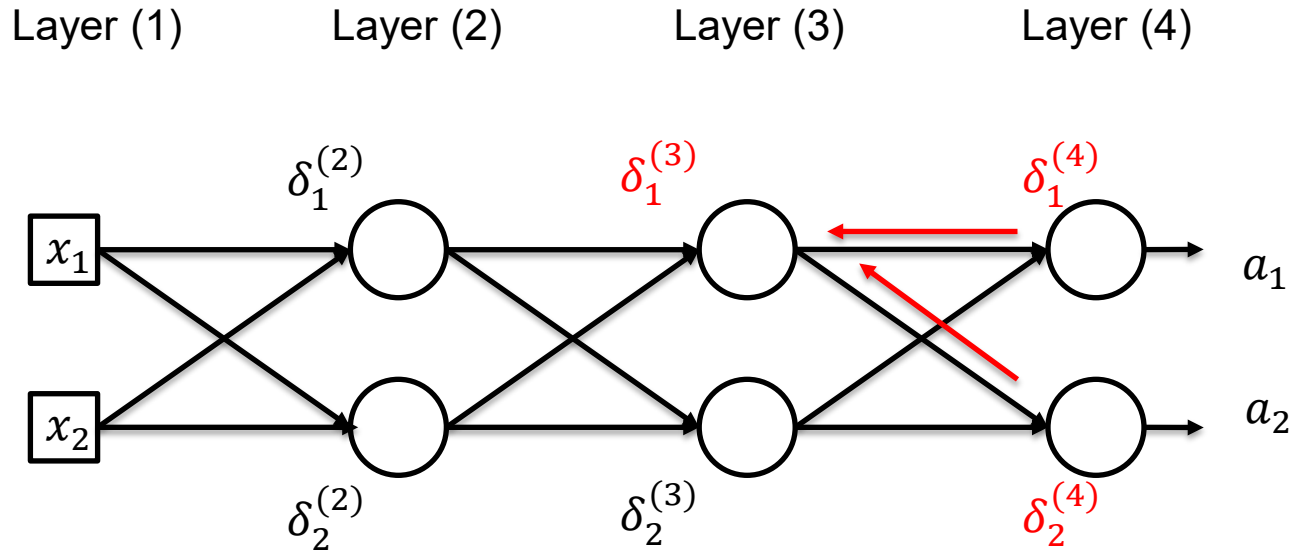

$$E_x = \|y - a\|^2$$

Thus, for any neuron in the network:

$$\delta_j^{(l)} = \sum_k \delta_k^{(l+1)} w_{kj}^{(l+1)} g'(z_j^{(l)})$$

$\delta_j^{(l)}$: δ of j^{th} Neuron in Layer l

$\delta_k^{(l+1)}$: δ of k^{th} Neuron in Layer $l + 1$

$g'(z_j^{(l)})$: derivative of j^{th} Neuron in Layer l w.r.t. its linear combination input

$w_{kj}^{(l+1)}$: Weight from j^{th} Neuron in Layer l to k^{th} Neuron in Layer $l + 1$

Gradient descent with Backpropagation

1. Initialize Network with Random Weights and Biases
2. For each Training Image:
 - a. Compute Activations for the Entire Network
 - b. Compute δ for Neurons in the Output Layer using Network Activation and Desired Activation

$$\delta_j^{(L)} = 2(y_j - a_j)a_j(1 - a_j)$$

- c. Compute δ for all Neurons in the previous Layers

$$\delta_j^{(l)} = \sum_k \delta_k^{(l+1)} w_{kj}^{(l+1)} a_j^{(l)} (1 - a_j^{(l)})$$

- d. Compute Gradient of Cost w.r.t each Weight and Bias for the Training Image using δ

$$\frac{\partial E_x}{\partial w_{jk}^{(l)}} = \delta_j^{(l)} a_k^{(l-1)}$$

$$\frac{\partial E_x}{\partial b_j^{(l)}} = \delta_j^{(l)}$$

Gradient descent with Backpropagation

3. Average the Gradient w.r.t. each Weight and Bias over the Entire Training Set

$$\frac{\partial E}{\partial w_{jk}^{(l)}} = \frac{1}{n} \sum \frac{\partial E_x}{\partial w_{jk}^{(l)}} \quad \frac{\partial E}{\partial b_j^{(l)}} = \frac{1}{n} \sum \frac{\partial E_x}{\partial b_j^{(l)}}$$

4. Update the Weights and Biases using Gradient Descent

$$w_{jk}^{(l)} \leftarrow w_{jk}^{(l)} - \eta \frac{\partial E}{\partial w_{jk}^{(l)}} \quad b_j^{(l)} \leftarrow b_j^{(l)} - \eta \frac{\partial E}{\partial b_j^{(l)}}$$

5. Repeat Steps 2-4 till Cost reduces below an acceptable level



THANK YOU

Some of the slides in these lectures have been adapted/borrowed from materials developed by Mark Craven, David Page, Jude Shavlik, Tom Mitchell, Nina Balcan, Matt Gormley, Elad Hazan, Tom Dietterich, Pedro Domingos, and Mohit Gupta.

