

CS/ECE 252: INTRODUCTION TO COMPUTER ENGINEERING

UNIVERSITY OF WISCONSIN—MADISON

Professor Guri Sohi
TAs: Newsha Ardalani and Rebecca Lam

Examination 4
In Class (50 minutes)
Wednesday, Dec 14, 2011
Weight: 17.5%

NO: BOOK(S), NOTE(S), CALCULATORS OF ANY SORT.

This exam has 12 pages, including a blank page at the end. Plan your time carefully, since some problems are longer than others. You must turn in pages 1 to 9.

LAST NAME: _____

FIRST NAME: _____

SECTION: _____

ID# _____

Question	Maximum Point	Points
1	3	
2	5	
3	4	
4	3	
5	5	
6	5	
7	5	
Total	30	

Q1. Syntax Errors in LC-3 Assembly Codes (3 points)

a. (1 pt) Circle any illegal labels in an assembly language program:

- ADD
- END
- .FILL
- BLKW
- OR
- NAND

b. (2 pt) The following program has multiple syntax errors. One of them, along with an explanation of the error, is indicated in the table below. In the two blank rows of the table, identify and explain two more syntax errors:

```
.ORIG x3000
LDI    R1, COUNT
AND    R1, R1, M1
LOOP   LEA    R0, x2FF
      ADD    R0, R1, R2
      BRz   LOOP
NOT    R1, R1, R1
HALT
M1     .FILL x4000
COUNT .FILL #100
.END
```

Instruction	Error
AND R1, R1, M1	AND reg, reg, label is illegal
LOOP LEA R0, x2FF	x2FF is > PCoffset9 field for LEA
NOT R1, R1, R1	NOT reg, reg, reg is illegal

Q2. (5 points)

An assembly language LC-3 program is given below:

```

        .ORIG      x3000
L1      LEA        R1, L1
        AND        R2, R2, x0
        ADD        R2, R2, x3
        LD         R3, P1
L2      LDR        R0, R1, xC
        TRAP       x21          ; OUT (Write char)
        ADD        R3, R3, #-1
        BRz        GLUE
        ADD        R1, R1, R2
        BRnzp     L2
GLUE    HALT
P1      .FILL      x7
        .STRINGZ   "GWHoeiolTdchboeymreee"
        .END
    
```

- a. Fill in the symbol table created by the first pass of the assembler on the above program. **(2 points)**

Symbol Name	Address
L1	x3000
L2	x3004
GLUE	x300A
P1	x300B

- b. After the program is assembled and loaded, what binary pattern is stored in memory location x3005? **(1 point)**

TRAP x21 -> 0xF021 -> 1111 0000 0010 0001

- c. What is the output of this program?**(2 points)**

Goodbye

Q3. (4 points)

We want the following code to shift the value at memory location M1 to the left by the number of bits stored at memory location M2, but there is **one** error in this code.

```
        .ORIG      x3000
        LD         R1, M1
        LD         R2, M2
LOOP    BRz        DONE
        ADD        R2, R2, #-1
        ADD        R1, R1, R1
        BR         LOOP
DONE    HALT

M1      .FILL      x000C
M2      .FILL      x0008
        .END
```

1. How many times does the instruction labeled LOOP get executed? Explain. **(2 points)**
 $16 - 2 + 1 = 15$ times
2. What is wrong with this program ? Explain. **(2 point)**
ADD R2, R2, #-1 and ADD R1, R1, R1 are misplaced, they should exchange their location.

Q4. Trap Handling (3 points)

The figure shown below represents the flow control from a user program to an OS service routine and back when a trap instruction is called. The flow control goes from A within a user program, to B, the operating system service routine, and back to the user program C. Fill out the the three empty boxes below corresponding with question marks. Boxes 1 and 2 should be filled with addresses and box 3 should be filled with an instruction. Write your answers in hexadecimal.

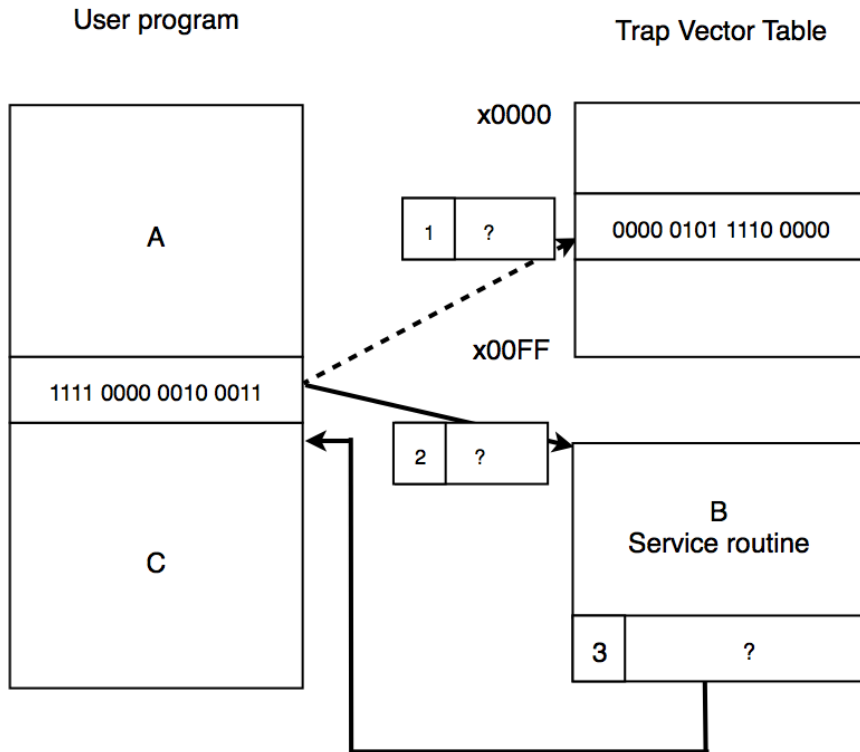

1	2	3
x0023	x05E0	xC1C0

Q5. Traps and subroutines (5 points)

An LC-3 programmer wrote the code below to read 10 single-digit decimal numbers from the keyboard, compute their average, and display the ceiling of the resultant average on the monitor.

Fill in the blanks below with assembly code to complete the program.

```

                .ORIG      x3000

                AND        R2, R2, #0          ; R2 keeps track of the sum
                LD         R6, CHtoD          ; Char->Digit template
                LD         R5, DtoCH          ; Digit->Char template
                LD         R7, COUNT          ; Initialize to 10
                ST         R7, SAVEDREG        ; Save ?? upon call of trap
AGAIN          TRAP        x23                ; Get char
                LD         R7, SAVEDREG        ; Restore ?? before continuing
                ADD        R0, R0, R6          ; Convert to number
                ADD        R2, R2, R0          ; Add the new number to the sum
                ADD        R7, R7, -1         ; Decr counter
                ST         R7, SAVEDREG        ;
                BRp        AGAIN              ; More digit?
                LD         R1, COUNT          ;
                JSR        DIV                 ;
                ADD        R0, R0, R5          ; Convert to char
                TRAP        x21                ; Output char
                HALT

; DIV subroutine
; Args: R2,R1  RET: R0=R2/R1

DIV            AND        R0, R0, #0          ; Initialize to 0
                NOT        R1, R1             ;
                ADD        R1, R1, #1         ; Negate R1
LOOPDIV        ADD        R0, R0, #1
                ADD        R2, R2, R1
                BRP        LOOPDIV
                RET

DtoCH          .FILL      x0030
CHtoD          .FILL      xFFD0
COUNT         .FILL      #10

SAVEDREG       .BLKW      1
                .END
```

Q6. Short Answer Questions (5 points)

Answer the following short answer questions in **one or two** sentences.

1. What problem could occur if the keyboard hardware does not check the DSR before writing to the DDR? (1 point)

The DSR bit 15 indicates when the last character written in the DDR has been read by the display, so if we don't check we could overwrite the previous value before it has been displayed by the monitor.

2. What is the difference between asynchronous and synchronous I/O? (1 point)

Asynchronous I/O:

Data is not sent at a fixed rate

Needs some method of synchronization (e.g. handshaking) with the processor

Synchronous I/O

Data is sent at a fixed rate

Doesn't need additional synchronization

3. What is the difference between memory mapped I/O and special I/O instructions? (1 point)

Memory mapped I/O has reserved locations in memory that store the addresses of the I/O devices and corresponding registers whereas special I/O instructions use special opcodes for I/O.

4. Give one potential benefit and one potential drawback of RFID implants (2 points).

Benefits: storage of personal health information, usage as personal ID

Drawbacks: privacy concerns, concerns about body integrity

Q7. General Questions (5 points, 1 point each)

Circle the **best** answer for the following questions about LC-3:

1. Which of the following can be used only once per file?
 - a. .STRINGZ
 - b. .BLKW
 - c. .ORIG
 - d. .FILL

2. Which of the following is true about “callee-save”?
 - a. Used by calling routine to save and restore registers that will be used in the routine
 - b. Save R7 before calling TRAP
 - c. Save R0 before calling TRAP x23
 - d. Used by called routine to save registers used by the routine

3. Suppose the instruction JSR label is stored at memory location x3000. After the instruction is executed, which of the following is true if label=x3050 and R7=x4000 before execution?
 - a. R7 = x3050
 - b. R7 = x3001
 - c. R7 = x3000
 - d. R7 = x4000

4. Which bit in the KBSR is the interrupt enable bit?
 - a. 15
 - b. 14
 - c. 13
 - d. 12

5. Which of the following is **not true** about interrupt driven I/O?
 - a. The device controls the interaction by sending a special signal to the processor when it is ready
 - b. It is more efficient than polling
 - c. It has built in priority levels for different device requests
 - d. The processor must routinely check the status register for the device until new data arrives or the device is ready