

Sample Questions for Part 3 (“How do modern computers work?”) of CS 202

Question 1: Do you know a little bit?

Specify whether each of the following statements is true or false. Feel free to explain your answers.

- _____ The binary number 00110 is 8 in decimal.
- _____ The decimal number 19 is 010111 in binary.
- _____ The binary number 001000 has the same value as the binary number 100.
- _____ Exactly 8 unique unsigned integers can be represented in 3 bits.
- _____ Exactly 31 unique unsigned integers can be represented in 5 bits.
- _____ Exactly 2^N different unsigned integers can be represented in N bits.
- _____ Exactly N^2 different unsigned integers can be represented in N bits .
- _____ The largest (unsigned) integer that is represented with 4 bits is 15 (decimal).
- _____ The number 0110 is larger in base ten than in base two.
- _____ The binary number 0010 divided by 2 (decimal) is 0001.
- _____ The binary number 01000 divided by 2 (decimal) is 00110.
- _____ The binary number 011001000 divided by 2 (decimal) is 001100100.
- _____ 3021 is a valid number in a base-4 representation.
- _____ 1008 is a valid number in a base-8 (octal) representation.
- _____ 49abc is a valid number in a base-16 (hexadecimal) representation.

Question 2: Can you handle the truth?

You are hired at a company where your boss only understands truth tables and cannot understand Boolean expressions or circuits. Every time a Boolean expression or circuit crosses his desk, he asks you to convert it to a truth table in standard form (where all input combinations are exhaustively enumerated **in order**).

- A) Draw the truth table for the Boolean expression:
 $D = (\text{NOT } A \text{ and } B \text{ and } C) \text{ OR } (\text{NOT } A \text{ and } \text{NOT } B) \text{ OR } (\text{NOT } C).$

- B) Draw the truth table for the Boolean expression: $C = \text{NOT } (A \text{ and } B).$

- C) Draw the truth table for this combinational circuit with three inputs, A, B, and C, and one output, D.

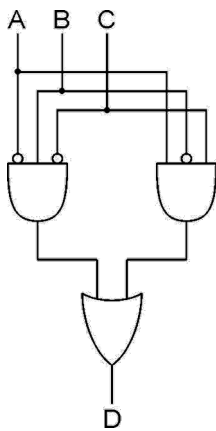

D) Draw the truth table for an implementation of a one-bit full adder.

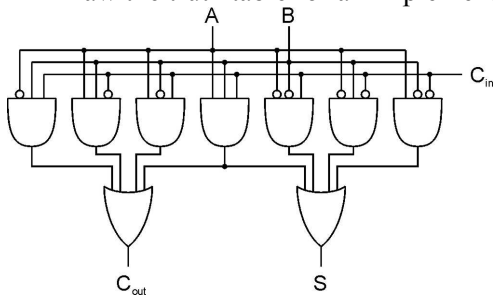

E) Label the four outputs of this circuit and draw the corresponding truth table.

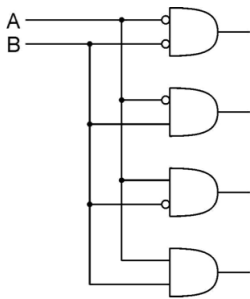

F) Consider the following sequential circuit with two inputs Set and Reset and one output M. Note that this circuit has a feedback loop and can therefore remember values. Draw the corresponding truth table; make sure you consider the output of the circuit also as an additional input.

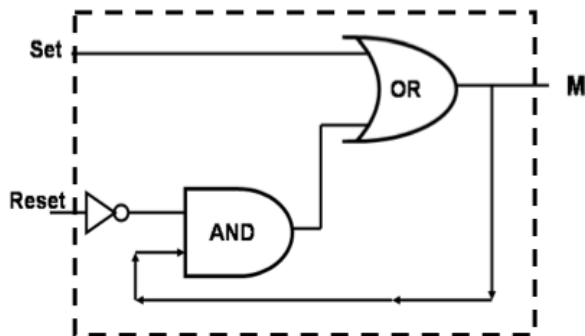

G) This question isn't related to truth tables. Your boss just needs help adding. Assume that a four bit adder is constructed from four full one-bit adders as shown below.

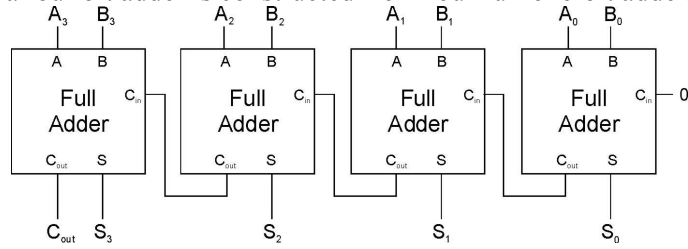

Given the following input, what would be the observed output? Fill in the table below.

A ₃	A ₂	A ₁	A ₀	B ₃	B ₂	B ₁	B ₀	C _{out}	S ₃	S ₂	S ₁	S ₀
0	1	0	1	0	0	1	0					
0	1	0	1	1	0	0	0					
0	1	0	1	0	0	1	1					
1	1	0	0	1	1	1	1					

Question 3: Do you remember me?

Imagine you have 4x3 bit DRAM with the following contents:

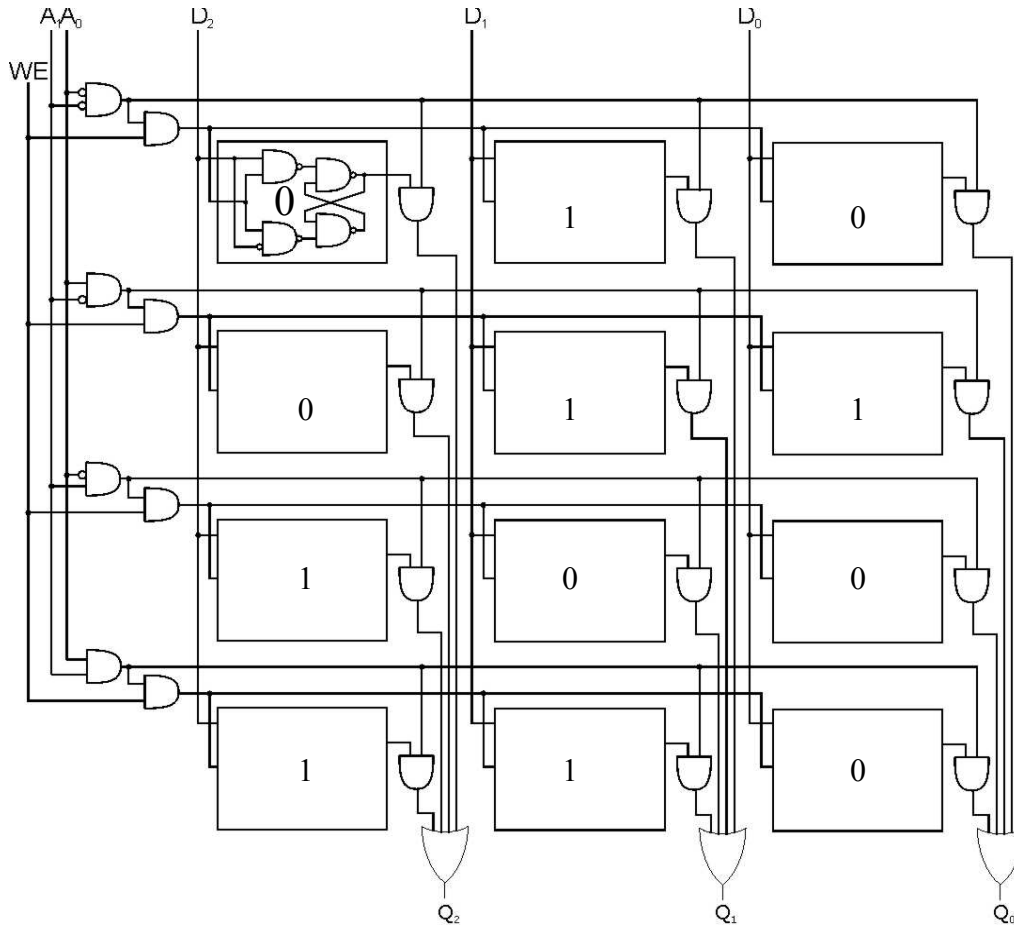

A) Imagine the following commands are sent to DRAM. What will be the output of the circuit in each case?

WE	A ₁	A ₀	D ₂	D ₁	D ₀	Q ₂	Q ₁	Q ₀
0	0	0	0	0	0			
0	1	0	1	1	1			
0	1	1	0	0	0			
1	0	0	1	1	0			
1	1	0	0	1	0			
0	0	0	1	1	1			

Question 4: Networking with your Friends

For each of the following questions #1-10, designate whether the statement is True or False

- 1) TCP/IP (Transmission Control Protocol/Internet Protocol) routes all messages through a single machine on the Internet.
- 2) TCP may divide a message into multiple packets before sending the packets through the network.
- 3) Different packets of the same message may be routed along different paths of the network between the sender and receiver.
- 4) TCP inserts a “sequence number” into every packet of a message.
- 5) TCP is able to handle packets of a message being re-ordered when sent through the network.
- 6) TCP is able to handle packets being dropped or lost when they are sent through the network.
- 7) If there is insufficient memory in a router within the network, a packet can be dropped.
- 8) If packets are received out of order, the receiver asks the sender to resend the misordered packets of the message.
- 9) TCP uses HTTP to help it resend packets of a message.
- 10) HTTP is used to ensure that eavesdroppers cannot read messages sent between a client machine and a web server.

Question 5: Failure is Impossible

- A) You are responsible for building a distributed service that must be able to handle at most 3 machines crashing (i.e., the machines will fail “fail-stop”). How many machines do you need within your service to keep the service available?
- a. 1
 - b. 3
 - c. 4
 - d. 5
 - e. 7
- B) You are responsible for building a distributed service that must handle at most 2 machines crashing **or giving wrong results**. How many machines do you need within your service to keep the service available?
- a. 2
 - b. 3
 - c. 4
 - d. 5
 - e. 7

Imagine you are on an island populated by two tribes. Members of one tribe always tell the truth. Members of the other tribe always lie. Tribe members can all recognize one another, but you can't tell them apart. For each of the following situations, determine which tribe each person is from. (We recommend creating a truth table to enumerate the possibilities.)

- C) You meet two people A and B from the island. A says, “ $1+1 = 3$.” B says, “ $1+1 = 2$.” What tribe is A from? What tribe is B from?
- a. A truth teller, B truth teller
 - b. A truth teller, B liar
 - c. A liar, B truth teller
 - d. A liar, B liar
 - e. Can't identify at least one of the people
- D) You meet two people C and D from the island. C says “We are not from the same tribe.” D says, “C is a liar.” What tribe is C from? What tribe is D from?
- a. C truth teller, D truth teller
 - b. C truth teller, D liar
 - c. C liar, D truth teller
 - d. C liar, D liar
 - e. Can't identify at least one of the people
- E) You meet two people E and F from the island. E says “F is a liar”. F says “E is a liar.” What tribe is E from? What tribe is F from?
- a. E truth teller, F truth teller
 - b. E truth teller, F liar
 - c. E liar, F truth teller
 - d. E liar, F liar
 - e. Can't identify at least one of the people

- F) You meet two people G and H from the island. G says “We are both liars.”
- a. G truth teller, H truth teller
 - b. G truth teller, H liar
 - c. G liar, H truth teller
 - d. G liar, H liar
 - e. Can't identify at least one of the people
- G) You meet two people J and K from the island. J says “K told me that he is a liar.” K says “J is a liar.”
- a. J truth teller, K truth teller
 - b. J truth teller, K liar
 - c. J liar, K truth teller
 - d. J liar, K liar
 - e. Can't identify at least one of the people