

**CS/ECE 252: INTRODUCTION TO COMPUTER ENGINEERING**  
**UNIVERSITY OF WISCONSIN—MADISON**

**Prof. Mark D. Hill and Prof. Gurindar Sohi**

**TAs: Rebecca Lam, Preeti Agarwal, Mona Jalal, Pradip Vallathol**

*Midterm Examination 2*

*In Class (50 minutes)*

*Wednesday, March 13, 2013*

*Weight: 17.5%*

**NO: BOOK(S), NOTE(S), OR CALCULATORS OF ANY SORT.**

The exam has 9 pages. **Circle your final answers.** Plan your time carefully since some problems are longer than others. You **must turn in the pages 1-8.**

LAST NAME: \_\_\_\_\_

FIRST NAME: \_\_\_\_\_

ID# \_\_\_\_\_

<b>Problem</b>	<b>Maximum Points</b>	<b>Points Earned</b>
<b>1</b>	6	
<b>2</b>	2	
<b>3</b>	2	
<b>4</b>	6	
<b>5</b>	2	
<b>6</b>	2	
<b>7</b>	2	
<b>8</b>	4	
<b>9</b>	4	
<b>Total</b>	30	

### Problem 1

(6 Points)

For the following questions, select the **best** answer. Choose only **one answer per question**.

- i. Which of the following is **not** true about an instruction?
  - a. Its format is specified in the Instruction Set Architecture (ISA).
  - b. Looks different from data in its representation.
  - c. Specifies the opcode and operands to be used in its execution.
  - d. Specifies an operation which is executed completely or not at all.
  
- ii. In which phase of the instruction cycle is the PC incremented?
  - a. **FETCH**
  - b. DECODE
  - c. EXECUTE
  - d. STORE RESULT
  
- iii. Which of the following is true about the FETCH OPERANDS phase of the instruction cycle?
  - a. Reads data from register files.
  - b. Loads data from memory.
  - c. **Both (a) and (b).**
  - d. None of the above.
  
- iv. How many instructions are executed per second by a machine which has a clock frequency of 80MHz and takes 5 cycles to execute an instruction?
  - a. 0.20
  - b. 0.25
  - c. **16,000,000**
  - d. 15,000,000
  
- v. Which of the following is **not** true about a decoder?
  - a. Two outputs of a decoder cannot be high at the same time.
  - b. **It acts like a MUX that has been connected in reverse.**
  - c. At least one output is high for any combination of inputs.
  - d. It has more output lines than input lines.
  
- vi. How many D-latches do we need to build a memory with an addressability of 8 bits and an address space of 256 locations?
  - a. 256
  - b. 1024
  - c. **2048**
  - d. 4096



**Problem 4**

**(6 Points)**

Design a finite state machine (FSM) that recognizes the pattern "101" among a sequence of input bits (IN). When the FSM has "101" as inputs in successive bits, it should output 1. Otherwise, the output should be 0. The bits are read from left to right. For example, for the input sequence 0101101010, the FSM output should be 0001001010.

- a. **Complete the state diagram below.** Each state is represented by two bits,  $S_1S_0$ . For example, the state marked as "01" has  $S_1 = 0$  and  $S_0 = 1$ . Clearly show all possible state transitions and the output (Z) at each state. The transitions for the initial state "00" have been completed for you. Assume that "11" is the state in which the sequence "101" is detected.

**(4 Points)**

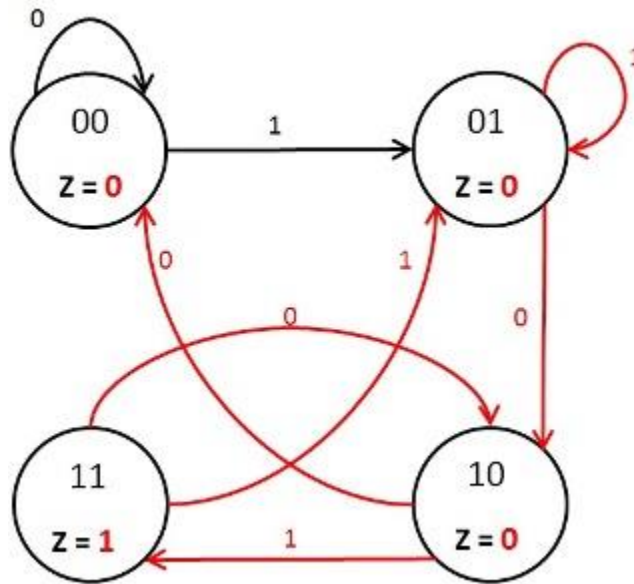

- b. Fill out the following **Next State truth table** for the above state diagram where  $S_1'S_0'$  represents the next state.

**(2 Points)**

$S_1$	$S_0$	IN	$S_1'$	$S_0'$
0	0	0	0	0
0	0	1	0	1
0	1	0	1	0
0	1	1	0	1
1	0	0	0	0
1	0	1	1	1
1	1	0	1	0
1	1	1	0	1

**Problem 5****(2 Points)**

List and describe briefly the several basic components of the von Neumann model.

**Memory** – Unit where data and instructions are stored.

**Processing Unit** – Actual processing of the information takes place.

**Input** – Devices for getting data in to computer memory.

**Output** – Devices for getting data out of computer memory.

**Control Unit** – Orchestrates execution of the program.

**Problem 6****(2 Points)**

For the following truth table, with inputs A, B, C and output Z, draw the gate level circuit using NOT gates and 3-input AND/OR gates.

A	B	C	Z
0	0	0	1
0	0	1	0
0	1	0	0
0	1	1	1
1	0	0	0
1	0	1	0
1	1	0	1
1	1	1	0

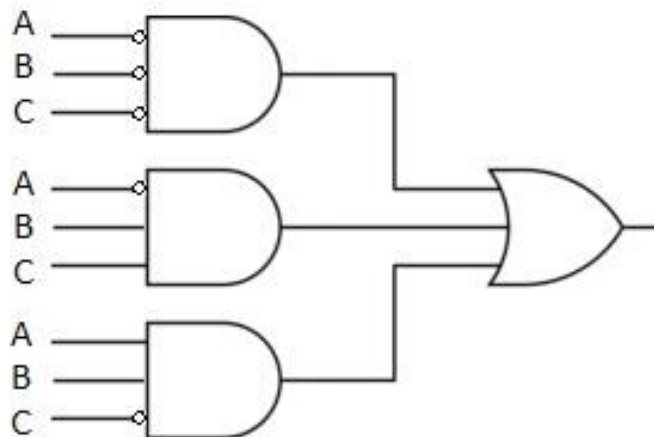

**Problem 7**

**(2 Points)**

In the von Neumann model, list the **two** interface registers involved in all memory accesses and describe the purpose of each of them.

**MAR** – contains the address of the memory location that is to be accessed.

**MDR** – contains the data that has to be written or has been read.

**Problem 8**

**(4 Points)**

Suppose the following is used to represent a 2:1 multiplexer:

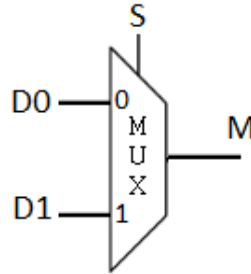

Where **S** is the select line, **D0** and **D1** are the inputs and **M** is the output.

Complete the truth table for the following combinational circuit that uses three 2:1 multiplexers, and has A, B, C as the inputs and Z as the output.

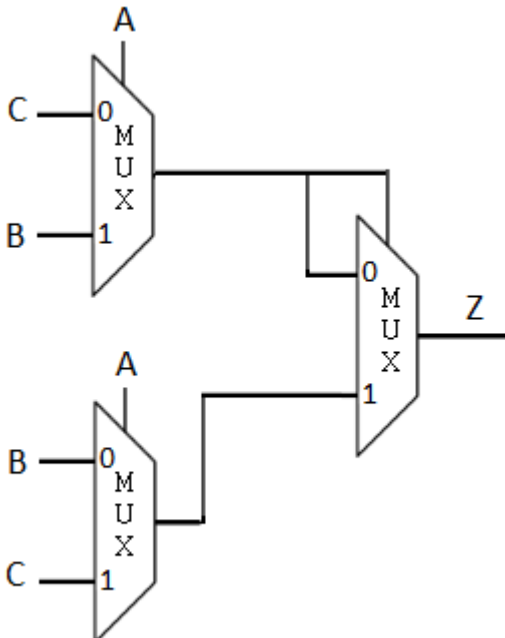

A	B	C	Z
0	0	0	0
0	0	1	0
0	1	0	0
0	1	1	1
1	0	0	0
1	0	1	0
1	1	0	0
1	1	1	1

**Problem 9****(4 Points)**

Complete the truth table for the following transistor-level circuit, where A, B, C are inputs and Z is the output.

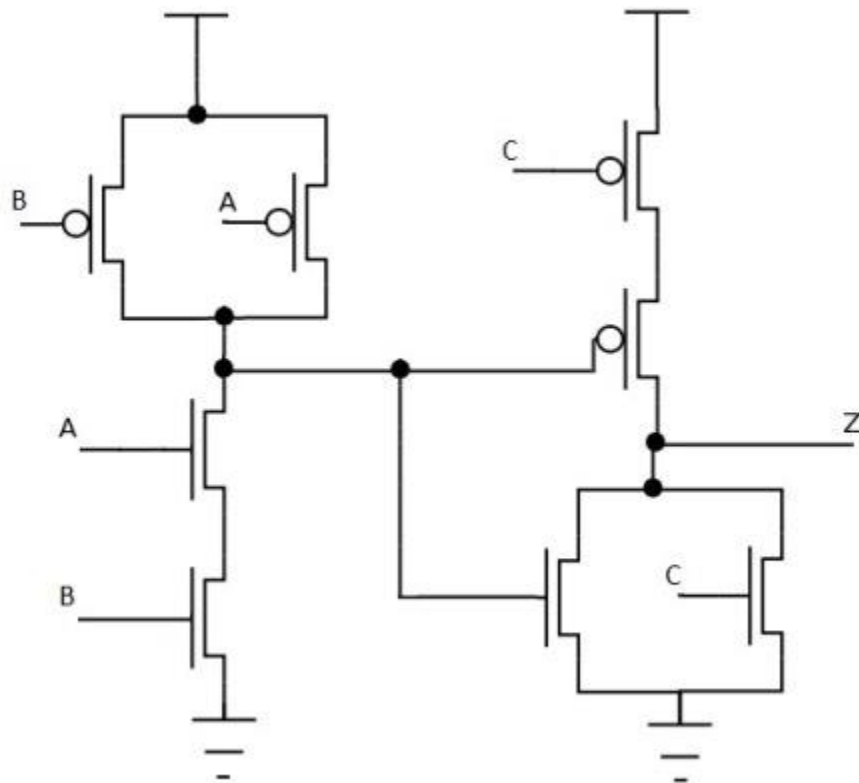

A	B	C	Z
0	0	0	0
0	0	1	0
0	1	0	0
0	1	1	0
1	0	0	0
1	0	1	0
1	1	0	1
1	1	1	0