

CS 744: DATACENTER AS A COMPUTER

Shivaram Venkataraman

Spring 2024

ANNOUNCEMENTS

- Assignments
 - Assignment zero is due!
 - Form groups for Assignment I on Piazza
- Class format
 - Review
 - Lecture
 - Discussion

Applications

Machine Learning

SQL

Streaming

Graph

Computational Engines

Scalable Storage Systems

Resource Management



Datacenter Architecture



OUTLINE

- Hardware Trends
- Datacenter design
- WSC workloads
- Discussion

WHY IS ONE MACHINE NOT ENOUGH?

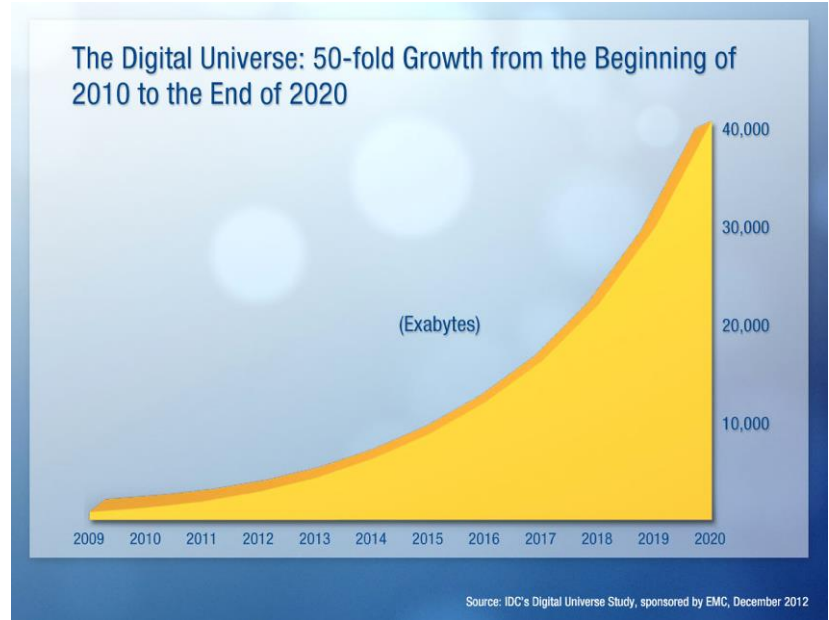

WHAT'S IN A MACHINE?

Interconnected compute and storage

Newer Hardware

- GPUs, FPGAs
- RDMA, NVlink

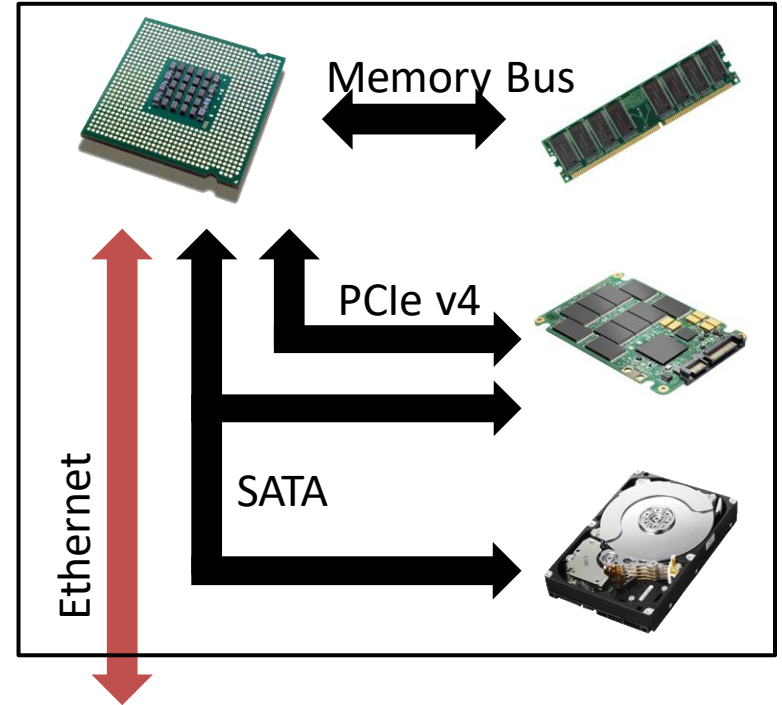

SCALE UP: MAKE MORE POWERFUL MACHINES

Moore's law

- Stated by Intel founder Gordon Moore
- Number of transistors on microchip double every **2 years**
- Today “**closer to 2.5 years**” Intel CEO Brian Krzanich

A persevering prediction

Number of transistors in CPU*
Log scale

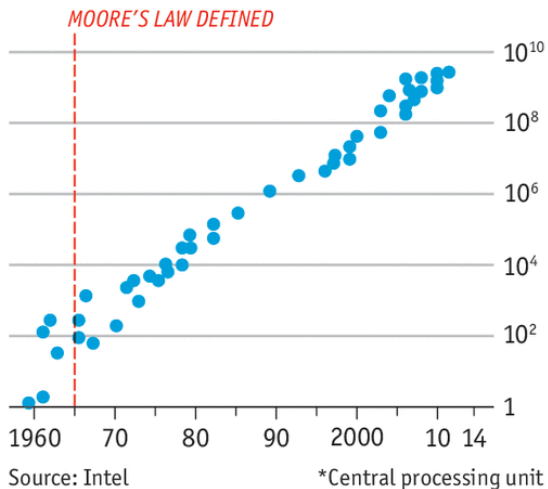

Source: Intel

*Central processing unit

DENNARD SCALING IS THE PROBLEM

Suggested that power requirements are proportional to the area for transistors

- Both voltage and current being proportional to length
- Stated in 1974 by Robert H. Dennard (DRAM inventor)

Broken since 2005

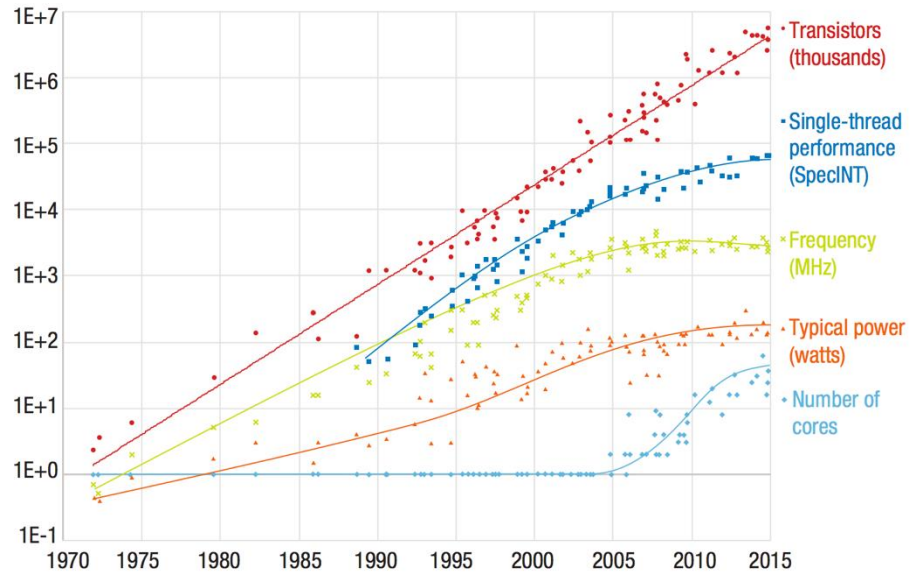

“Adapting to Thrive in a New Economy of Memory Abundance,” Bresnicker et al

DENNARD SCALING IS THE PROBLEM

Performance per-core is stalled

Number of cores is increasing

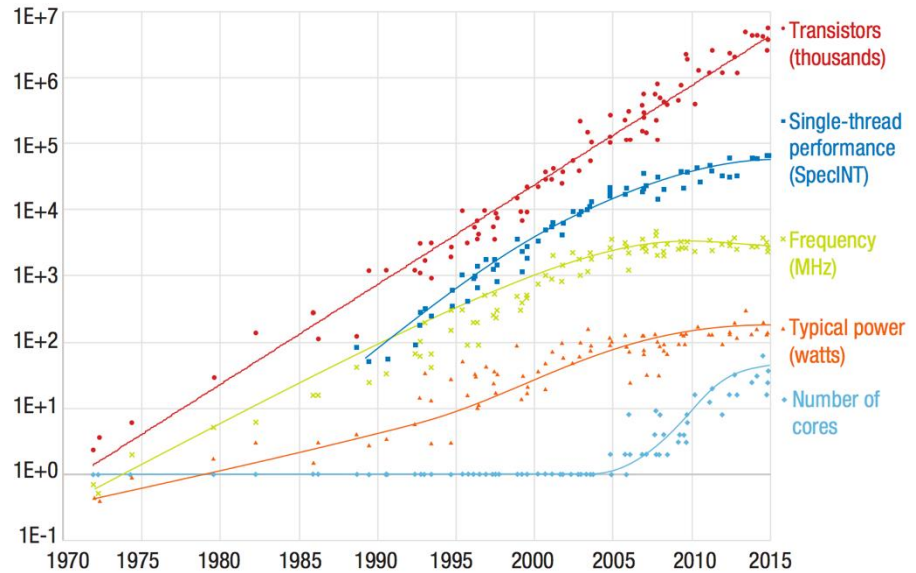

“Adapting to Thrive in a New Economy of Memory Abundance,” Bresniker et al

MEMORY TRENDS

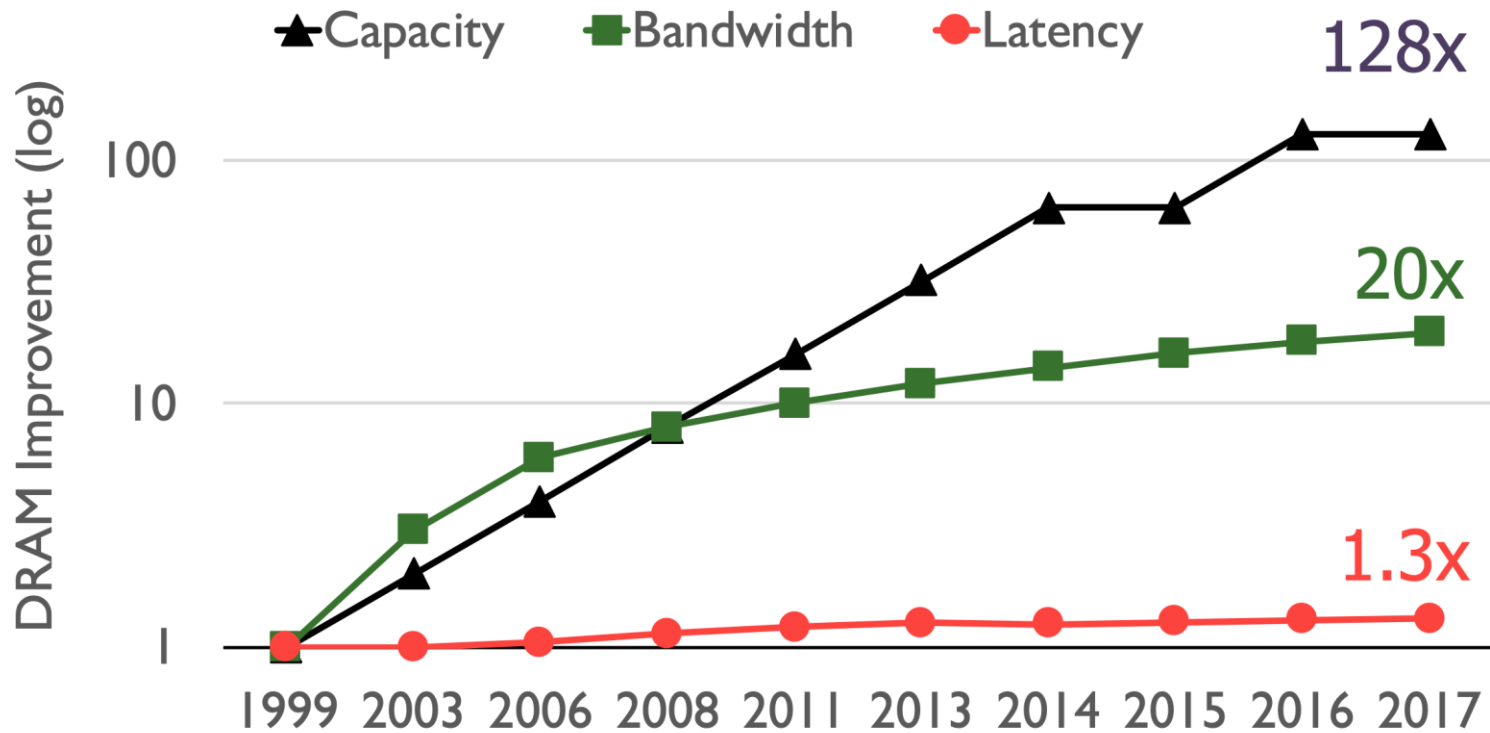

MEMORY TAKEAWAY

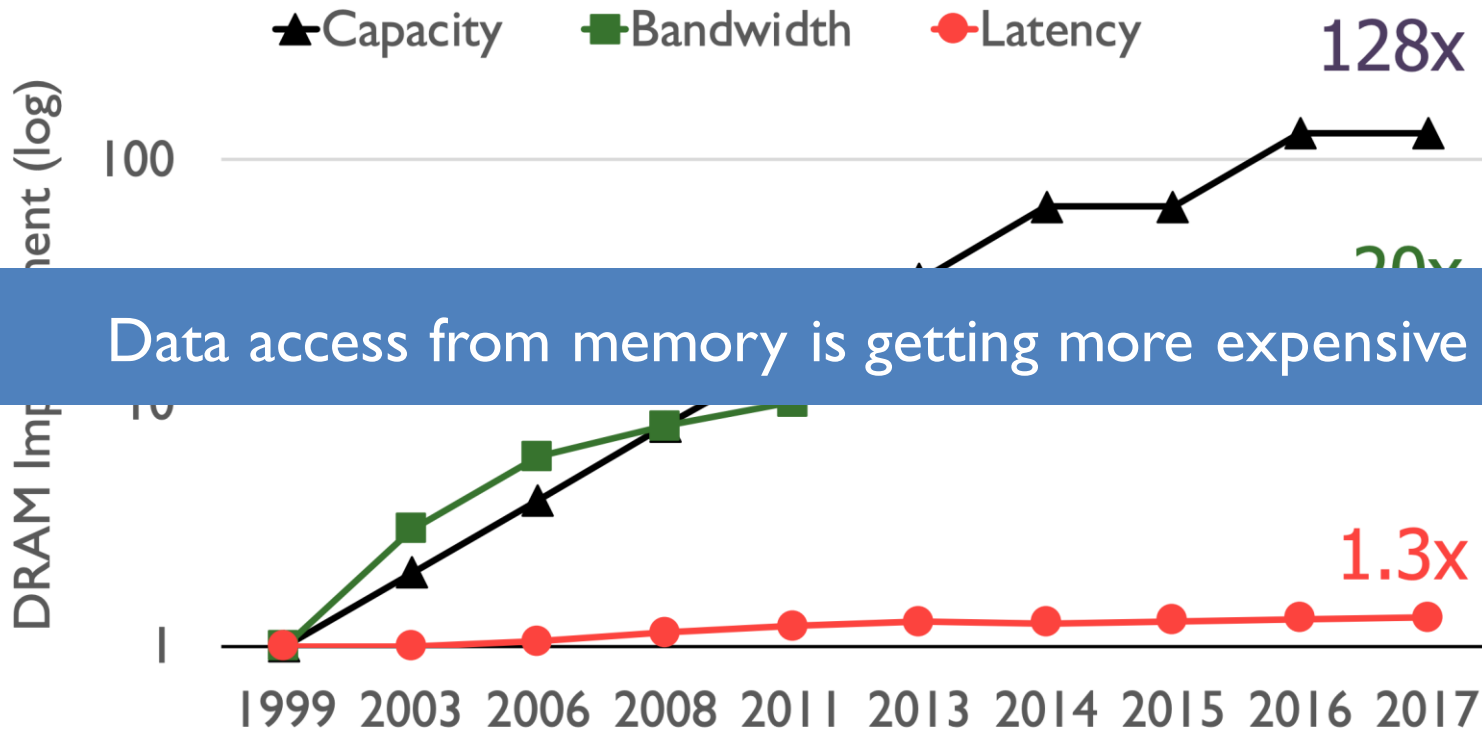

HDD CAPACITY

BackBlaze

Average Cost per Drive Size

By Quarter: Q1 2009 - Q2 2017



HDD BANDWIDTH

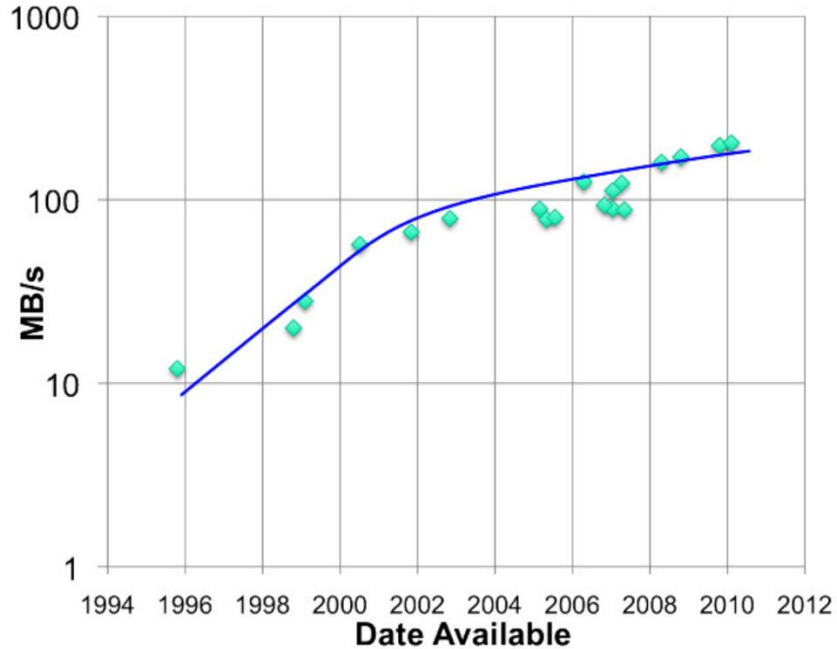

Figure 4: Maximum sustained bandwidth trend

Disk bandwidth is not growing

SSDS

Performance:

- Reads: 10-25us latency
- Write: 200us latency
- Erase: 1,5 ms

Steady state, when SSD full

- One erase every 64 or 128 reads (depending on page size)

Lifetime: 100,000-1 million writes per page

SSD VS HDD COST

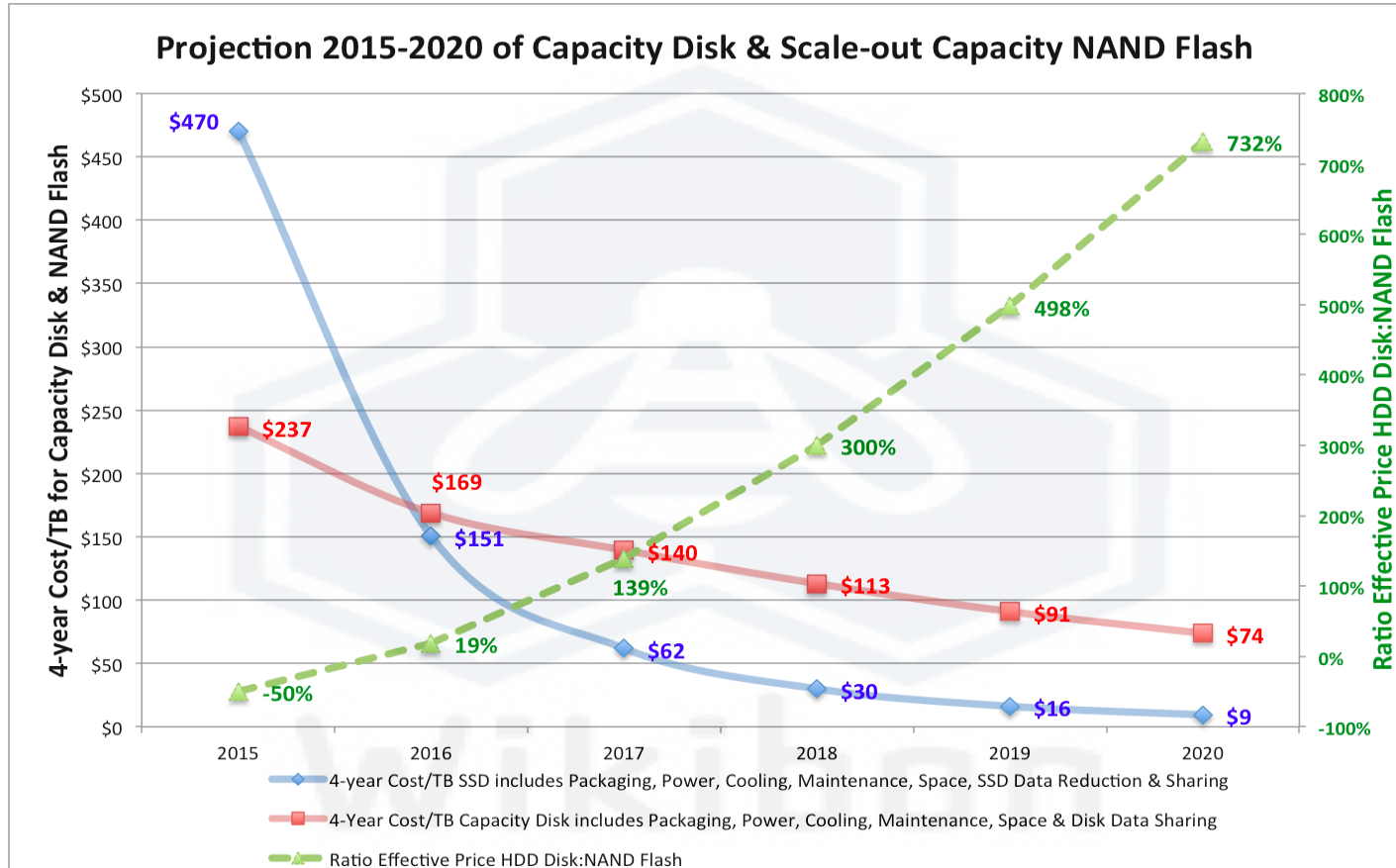

Source: © Wikibon 2015. 4-Year Cost/TB Magnetic Disk & SSD, including Packaging, Power, Maintenance, Space, Data Reduction & Data Sharing

ETHERNET BANDWIDTH

Growing **33-40%** per year !

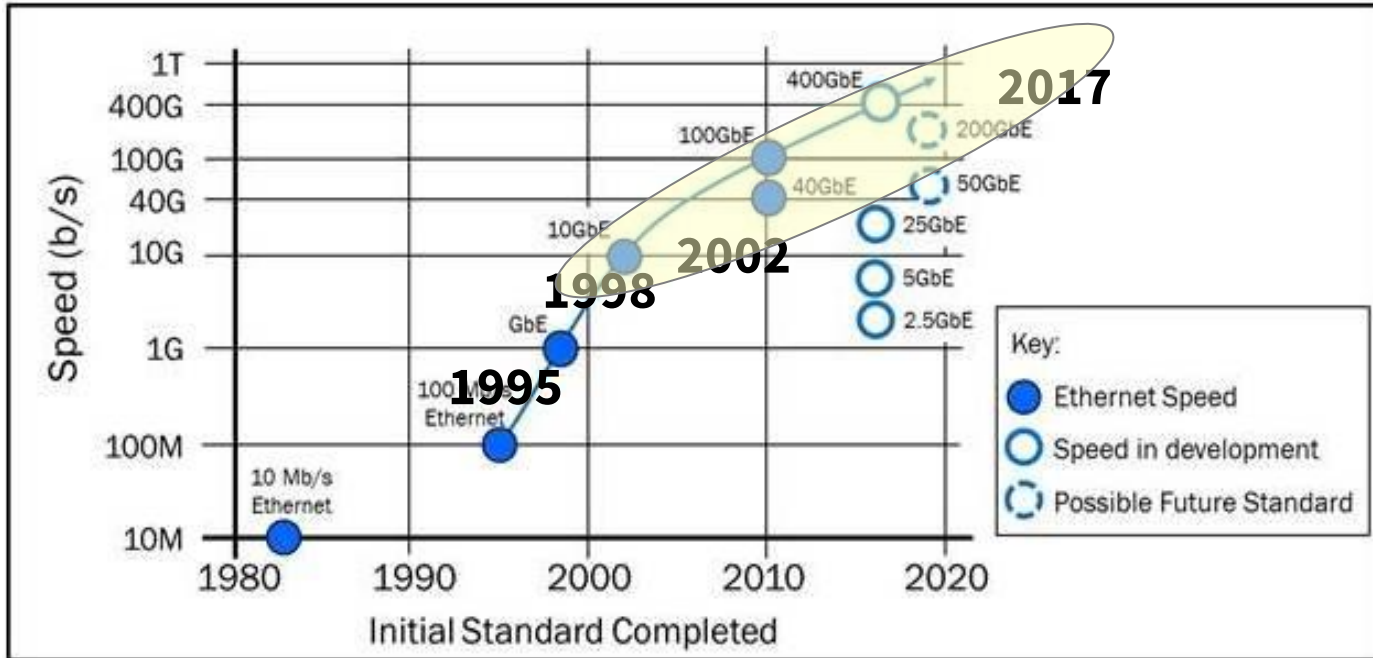

AMAZON EC2 (2019)

New – EC2 P3dn GPU Instances with 100 Gbps Networking & Local NVMe Storage

HARDWARE EVOLUTION

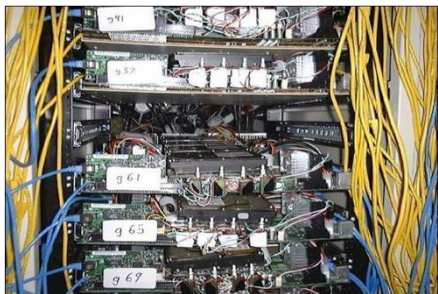

Commodity CPUs
Lots of disks
Low bandwidth network
(2001 Google)



GPUs – Graphics Cards
Lots of parallelism
Bigger power footprint
Expensive!
(~2010)

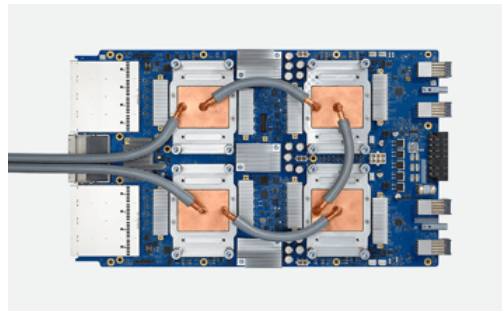

TPUs, FPGAs, ASICs
ML specialized hardware
(~2020)

TRENDS SUMMARY

CPU speed per core is flat

Memory bandwidth growing slower than capacity

SSD, NVMe replacing HDDs

Ethernet bandwidth growing

New accelerators

SCALE OUT: DATACENTER ARCHITECTURE

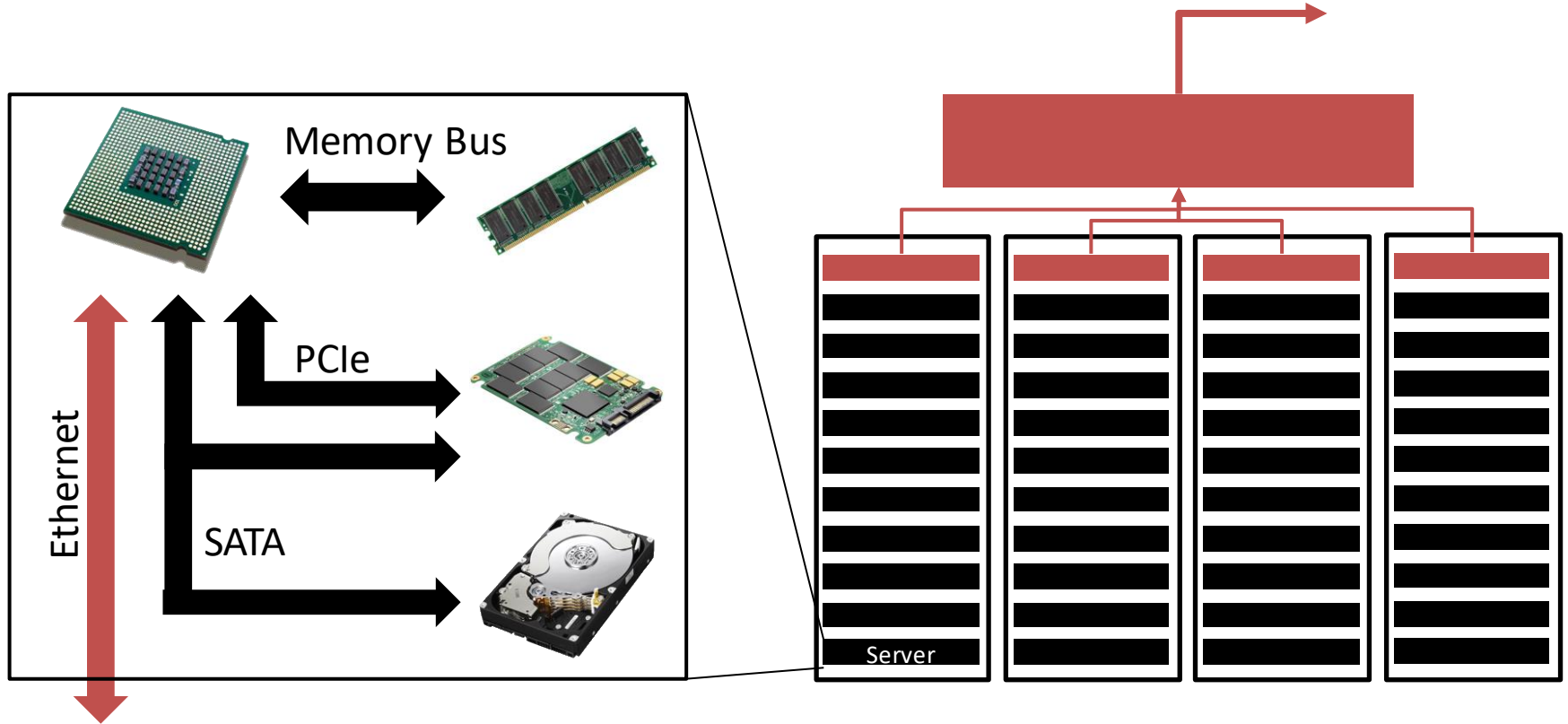

STORAGE HIERARCHY (DC AS A COMPUTER V2)

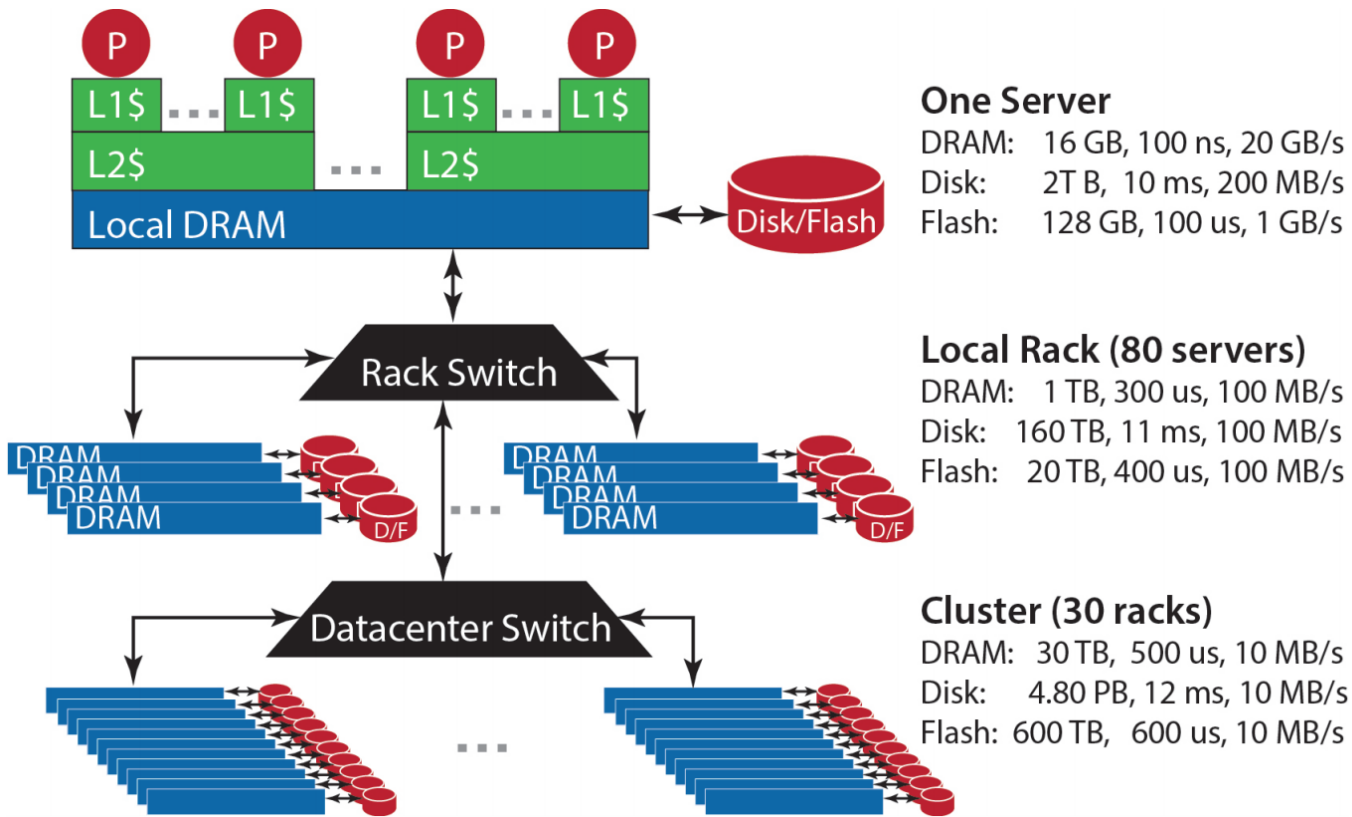

One Server

DRAM: 16 GB, 100 ns, 20 GB/s

Disk: 2T B, 10 ms, 200 MB/s

Flash: 128 GB, 100 us, 1 GB/s

Local Rack (80 servers)

DRAM: 1 TB, 300 us, 100 MB/s

Disk: 160 TB, 11 ms, 100 MB/s

Flash: 20 TB, 400 us, 100 MB/s

Cluster (30 racks)

DRAM: 30 TB, 500 us, 10 MB/s

Disk: 4.80 PB, 12 ms, 10 MB/s

Flash: 600 TB, 600 us, 10 MB/s

WAREHOUSE-SCALE COMPUTERS

Single organization

Homogeneity (to some extent)

Cost efficiency at scale

- Multiplexing across applications and services
- Rent it out!

Many concerns

- Infrastructure
- Networking
- Storage
- Software
- Power/Energy
- Failure/Recovery
- ...

SOFTWARE IMPLICATIONS

Reliability

Storage Hierarchy

Workload Diversity

Single organization

WORKLOAD: PARTITION-AGGREGATE

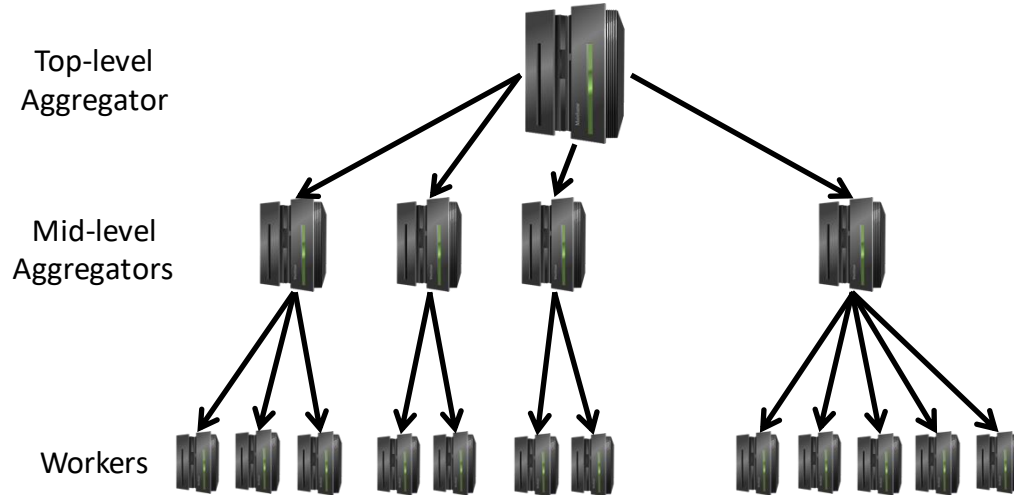

WORKLOAD: SCHOLAR SIMILARITY

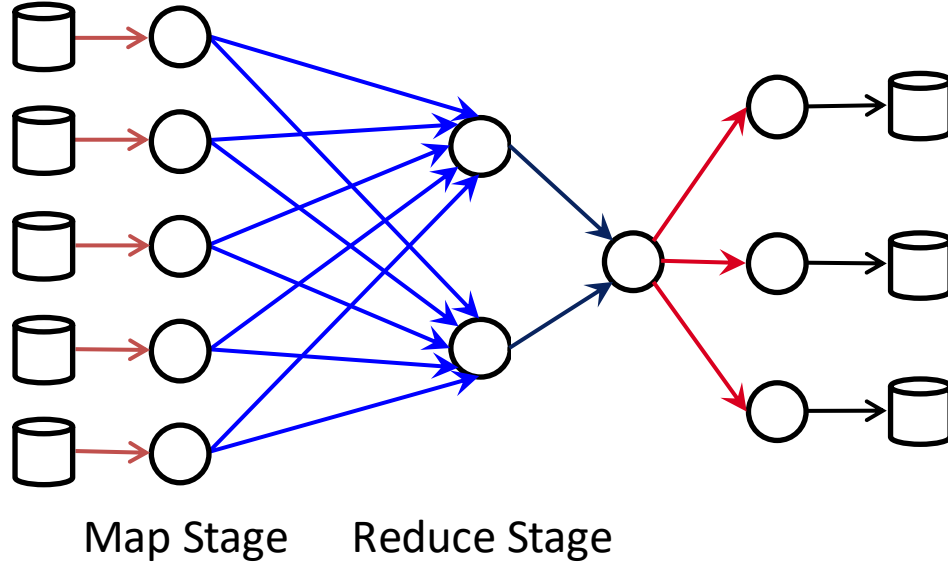

VIDEO ENCODING

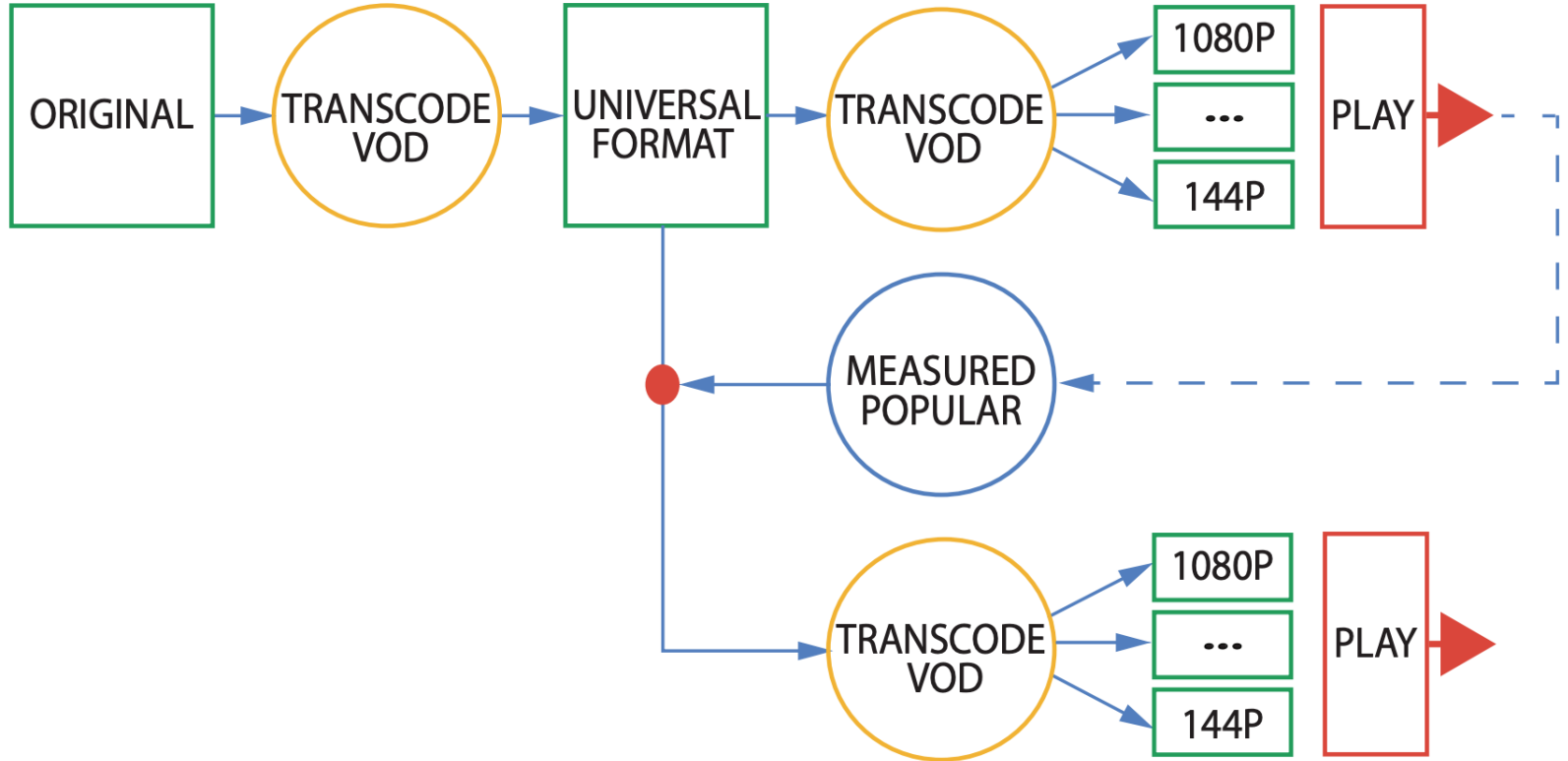

MACHINE LEARNING

Table 2.1: Six production applications plus ResNet benchmark. The fourth column is the total number of operations (not execution rate) that training takes to converge.

Type of Neural Network	Parameters (MiB)	Training			Inference
		Examples to Convergence	ExaOps to Conv	Ops per Example	Ops per Example
MLP0	225	1 trillion	353	353 Mops	118 Mops
MLP1	40	650 billion	86	133 Mops	44 Mops
LSTM0	498	1.4 billion	42	29 Gops	9.8 Gops
LSTM1	800	656 million	82	126 Gops	42 Gops
CNN0	87	1.64 billion	70	44 Gops	15 Gops
CNN1	104	204 million	7	34 Gops	11 Gops
ResNet	98	114 million	<3	23 Gops	8 Gops

DISCUSSION

<https://forms.gle/8f2kFrVW6jxTzYJeZ6>

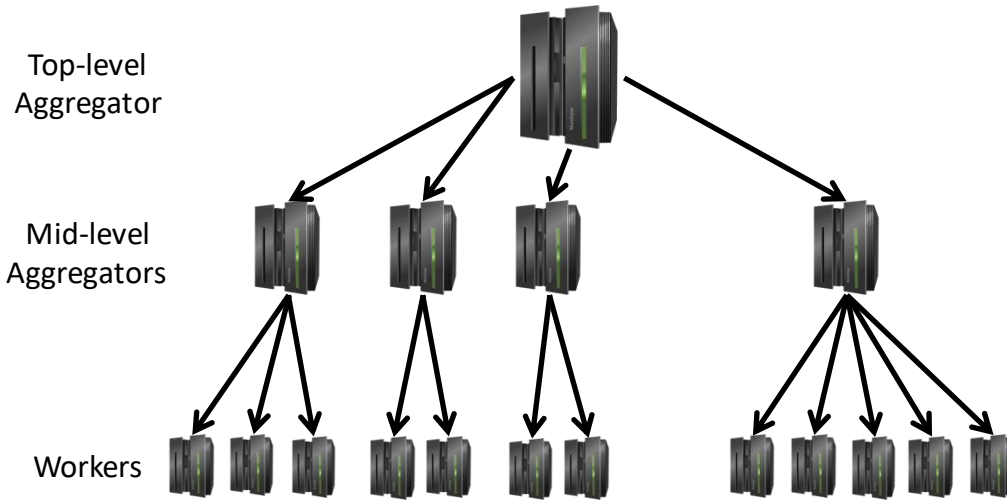
Scale-up vs Scale-out



DISCUSSION

Scale-up vs Scale-out

DISCUSSION

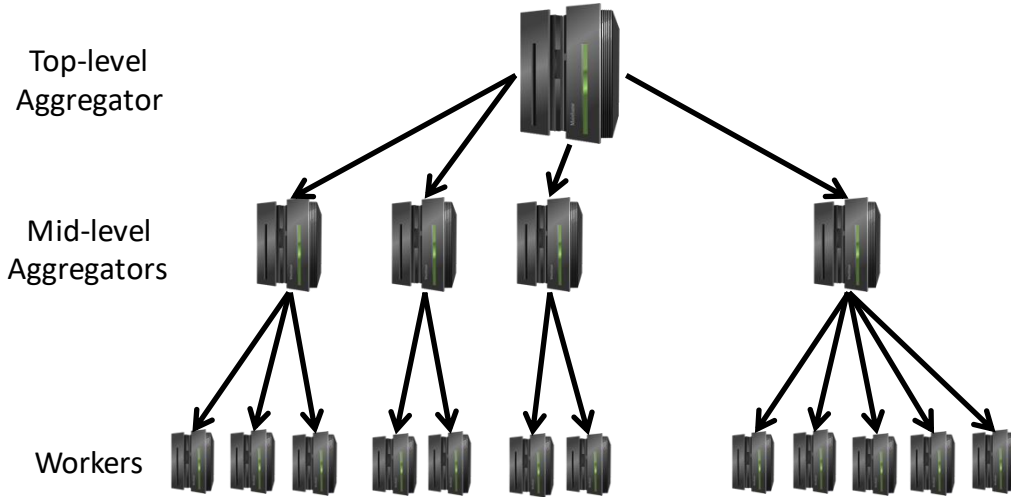
NEXT STEPS

Next class: Storage Systems

Assignment 1 out Tuesday.

Submit groups before that!